

**RHODE ISLAND
SOIL EROSION AND
SEDIMENT CONTROL
FIELD GUIDE**



ISSUED 2016

Rhode Island State Conservation Committee

With the Support from

Rhode Island Department of
Environmental Management

Rhode Island Coastal

Resources Management Council

Rhode Island Department of Transportation

The University of Rhode Island

Janet Coit, Director
(RI DEM)

Edited by Beverly Migliore (RI DEM) and
Brian Lafaille (RI DEM)

Project Coordination and Team Leader
J. Eric Scherer
Southern Rhode Island Conservation District

William Bailer (RI DEM),
Field Guide Layout and Design

Accessing the Field Guide:

Access the *Rhode Island Soil Erosion and Sediment Control Field Guide* will be managed through the following RI DEM web-site:

<http://www.dem.ri.gov/programs/water/permits/ripdes/stormwater/stormwater-manual.php>

An electronic (.pdf) version of the Handbook can be downloaded from this site.

For additional information concerning the Field Guide, contact:

Beverly Migliore, Supervising Environmental Scientist
Office of Customer and Technical Assistance
RI Department of Environmental Management
235 Promenade Street
Providence, RI 02908
Or by e-mail to DEM.SESCHHandbook@dem.ri.gov

Issued 2016



About this Field Guide...

This Field Guide is a companion document to the Rhode Island Soil Erosion and Sediment Control Handbook (2015 edition). This Field Guide is not intended to be an all-inclusive document. It is intended to be used for installation, inspection, and maintenance of control measures. Specific details addressing planning, design, and applicability of control measures can be found in the Handbook.

This Field Guide contains information on 45 of the most commonly used control measures that address Pollution Prevention and Good Housekeeping, Erosion Control, Runoff Control, and Sediment Control. It is a quick, handy, and portable document intended for use in the field.

This Field Guide had been designed to provide the user with guidance on installation of measures, maintenance of measures, inspection of measures, removal of measures, troubleshooting tips, as well as some good and bad practice visuals. This Guide reflects the best state of science and technology for control measures.

The user of this Field Guide (and Handbook) should ensure they are using the most current information available by subscribing to the Office of Water Resources (OWR) e-mail list. This list allows users to be informed on the most current guidance, policies, and new regulations regarding a variety of stormwater topics, which can be found at the user-friendly webpage at: <http://listserve.ri.gov/mailman/listinfo/owrinfo>.

Acknowledgements

The Technical Review Committee members' contribution of time and expertise in developing the State's SESC Field Guide is greatly appreciated. The membership of the committee consisted of the following individuals:

J. Eric Scherer, SRICD
Brian Lafaille, RI DEM
Eric Beck, RI DEM
Beverly Migliore, RI DEM
William Bailer, RI DEM
Jim Boyd, RI CRMC
Allison Hamel, RI DOT
Jeff Peterson, Vanasse Hangen Brustin, Inc.
Jason Normadin, E.J. Prescott
Peter Hanrahan, E.J. Prescott
Lorraine Joubert, URI
Lisa DeProspo Philo, URI
Emily Holland, RI DOT
Shawn M. Martin, Fuss and O'Neil
Chuck Eaton, CME Associates
Jason Ringler, Louise Berger
Sam Whitin, EA Engineering, Science, & Technology
Alan Gillespie, USDA, NRCS
Christopher Modisette, USDA, NRCS
Christine Odiaga, Mass DEP
Audie Osgood, DiPrete Engineering

To all who provided photographs and technical drawings: Graphics are individually cited, or are from the Rhode Island Soil Erosion and Sediment Control Handbook (2016 update).

Please Note:

Mention of trade names or proprietary commercial products, if any, does not constitute endorsement. Review by State of Rhode Island employees does not necessarily reflect the views and policies of state agencies, nor does the mention of trade names, commercial products or professional consultants constitute endorsement or recommendation for use or services by the State of Rhode Island.

Table of Contents

About This Field Guide.....

Acknowledgements.....

Introduction and Summary.....

Implementation: The Big Picture.....

Roles and Responsibilities.....

Soil Erosion and Sediment Control Plans

Control Measure Installation, Inspection and

Maintenance Requirements.....

Control Measures: Doing it Right!.....

Primary Measures: Minimizing Disturbance.....

Runoff Control: Minimizing Erosive Potential.....

Erosion Control: Stabilizing Soil Surfaces.....

Sediment Control: Keeping Sediment On-Site.....

Selecting Control Measures

Pollution Prevention &

Good Housekeeping.....

Minimizing Disturbed Area: Preserving Soils & Vegetation...

Protecting Vegetative Buffers.....

Limit of Work and Site Access Control.....

Tree Protection.....

Dust Control.....

Spill Prevention and Control Plans.....

Stockpile and Staging Area Management.....

Street Sweeping.....

Waste Management.....

Concrete Washout.....

Vehicle Fueling, Maintenance and Washing.....

Erosion Control Measures.....

Mulching.....

Soil Preparation and Topsoiling.....

Seeding for Temporary Vegetative Cover.....

Seeding for Permanent Vegetative Cover.....

Sodding.....

Landscape Planting.....

- Retaining Walls.....
- Slope Protection.....
- Surface Roughening.....

Runoff Control Measures.....

- Check Dams.....
- Water Bars.....
- Diversions.....
- Perimeter Dikes.....
- Lined Waterways.....
- Vegetated Waterways.....
- Temporary Lined Channel.....
- Pipe Slope Drain.....
- Grade Stabilization Structures.....
- Outlet Protection.....

Sediment Control Measures.....

- Inlet Protection.....
- Construction Entrances.....
- Temporary Sediment Basins.....
- Temporary Sediment Traps.....
- Temporary Stream Crossings.....
- Compost Filter Berms.....
- Silt Fence.....
- Straw Wattles, Compost Tubes and Fiber Rolls.....
- Straw Bale.....
- Turbidity Curtains.....
- Containment Area for Earth Materials.....
- Portable Sediment Tanks and Bags.....
- Pumping Settling Basins.....
- Pump Intake Protection.....

Introduction and Summary

This field guide has been developed for State and Municipal Regulators, Conservation Commission staff, Department of Public Works (DPW) staff, Planning Board staff, Contractors and Consultants for use in the field. **The field guide has three goals**, to help practitioners:

1. **Minimize erosive potential (runoff control),**
2. **Stabilize soil (erosion control), and**
3. **Keep sediment on site (sediment control).**

Sediment that washes off construction sites and into streams, lakes and wetlands is one of the largest water quality problems in Rhode Island. Sediment (and the toxicants associated with it) pollutes water, degrades plant and wildlife habitats and kills fish and other aquatic organisms. Such impacts are not only ecologically damaging, they are violations of the federal Clean Water Act, the state Fresh Water Wetlands Act and local bylaws and regulations. The RI State Conservation Committee under the direction of the Director of the Department of Environmental Management is dedicated to helping minimize such environmental degradation through education, outreach and advocacy.

Runoff, erosion, and sediment control are important at every phase of the construction process. Implementing the right control measures (rather than repair or restoration practices) saves money, time and the environment.

This field guide introduces the reader to commonly used control measures and helps the reader ask the right questions of the design and implementation professionals. More specifically, this field guide addresses:

- **Implementation of stormwater regulations**
- **Current Control Measures** for:
 - Runoff control,
 - Erosion control, and
 - Sediment control.

There are dozens of runoff, erosion and sediment control techniques and structures, each appropriate for different types of sites and applications. The available suite of techniques and structures evolves as technology and experience evolve. **Every project and situation must, therefore, be individually evaluated and addressed with a uniquely appropriate mix of Control Measures.** Keep in mind, however, that no amount of erosion or sedimentation control engineering can be effective on inherently unstable sites, or when improperly implemented or maintained.

10 STRATEGIES FOR EFFECTIVE EROSION & SEDIMENT CONTROL

Stop Erosion BEFORE It Starts

1. **Phase construction activities.** Sequence construction in order to minimize the area and time of soil exposure.
2. **Minimize disturbed areas.** Preserve natural vegetation whenever possible; it is the best and cheapest control.

Control Runoff ... Minimize Erosion Potential

3. **Control stormwater flowing onto and through the project site.** Divert flows around exposed soils; slow down stormwater flows; infiltrate stormwater on-site.

Control Erosion ... Keep Soil in Place

4. **Protect and stabilize disturbed soils and slopes** with mulch, seed, sod, or blankets.
5. **Break-up and reinforce disturbed soils and slopes** with mats, fiber logs, or bio-engineered solutions.

Control Sedimentation ... Keep Sediment On-Site

6. **Establish sediment barriers and storm drain sediment controls** to prevent sediment from leaving the site and entering resource areas.
7. **Stabilize construction exits** to keep sediment from being tracked onto adjoining streets.
8. **Use dewatering and turbidity control practices as needed.**

Maintain Controls Appropriately

9. **Regularly inspect and maintain all erosion and sediment controls** throughout the project site.
10. **Obey permit conditions** throughout the course of the project and **remove temporary Control Measures when surrounding soils are stabilized.**

- Preserve vegetation above slope and phase construction →
- Divert runoff around bare soil →
- Stabilize bare soil →
- Use sediment barriers →
- Protect slopes and channels from erosion →
- Install sediment traps →
- Preserve vegetation around wetlands and waterways →

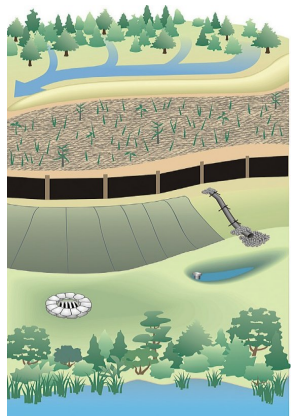

Implementation: The Big Picture

ROLES AND RESPONSIBILITIES

Designers and engineers are primarily responsible for:

- Developing designs that meet all applicable standards and are appropriate to the field conditions and wetland resource areas
- Developing solutions to problems that arise in the field

Contractors are primarily responsible for:

- Installing and maintaining appropriate sediment and erosion Control Measures and resolving problems identified in the field.

Inspectors and consultants are primarily responsible for:

- Reviewing plans and advising clients.
- Monitoring conditions and identifying problems in the field.

Regulators

Many different agencies, laws, and regulations address stormwater and, in so doing, address runoff, sedimentation and erosion. The following list does not include all potentially relevant agencies and/or regulations, and is intended to be used for general information and guidance only.

The RI Department of Environmental Management (RIDEM) through its ***Rhode Island Pollutant Discharge Elimination System (RIPDES) Stormwater Permit Program*** issues permits. The stormwater program was delegated to RI by the US Environmental Protection Agency. This program regulates stormwater discharges associated with Construction activities, specific Industrial activities, and Municipal Separate Storm Sewer Systems (MS4s); this field guide section addresses only Construction site issues.

The RIPDES permit program is authorized by Section 402 of the Federal Clean Water Act (CWA) which prohibits discharge of pollutants into navigable waters of the US except as in compliance with a RIPDES permit. The CWA requires that point source discharges of pollutants obtain permits. Most stormwater discharges are considered point sources and are therefore subject to a RIPDES permit.

Under RIPDES, ***construction sites disturbing 1 acre or more of land must*** meet the requirements of RIDEM's RIPDES Construction General Permit (CGP). RIDEM develops the General Permit and publishes its availability on it's website: www.dem.ri.gov . An "operator" is the person who controls the project's plans and specifications (owner/developer) as well as the person who controls the day-to-day operation of the project (general contractor). Owners and operators of discharges prepare a Stormwater Management Plan to comply with the general permit, submit a Notice of Intent (NOI) requesting authorization under the general permit, carry out the plan and other permit requirements and periodically assess their performance.

The CGP requires applicable facilities to **prepare a Soil Erosion and Sediment Control Plan** as part of the larger overall Stormwater Management Plan. See next section for details) and how to implement specific Control Measures, such as those described in this field guide.

RIDEM Phone Number:

401-222-4700

The RI Coastal Resources Management Council (CRMC) requires stormwater management including erosion and sediment control, for projects located within that agency's jurisdiction (i.e., on a shoreline feature or its 200-foot contiguous area, within a Special Area Management Plan (SAMP) boundary, freshwater wetlands in the vicinity of the coast or certain statewide threshold activities). The CRMC along with agency partners RIDEM and the RI Department of Administration developed the Rhode Island Coastal Non-Point Pollution Control Program (RICNPP) in July 1995 to comply with the requirements of section 6217(g) of the 1990 Coastal Zone Management Act reauthorization. Existing CRMC regulations comply with the federal requirements to address stormwater management and erosion and sediment control for new development projects within the state.

RI CRMC Phone Number:

401-783-3370

US Army Corps of Engineers (USACE), under Section 404 of the Clean Water Act, issues "**404 Permits**" that regulate the discharge of dredged or fill material into waters of the US.

US ACOE Phone Number:

1- 800-343-4789

Other Local Authorities may have responsibility for regulating or permitting land disturbance or construction activities. Please check with your municipality for pertinent local standards or regulations.

Soil Erosion and Sediment Control Plans

A Soil Erosion and Sediment Control (SESC) Plan is a site-specific document that describes the potential for soil erosion and sedimentation to occur on a construction project. It explains and illustrates the Control Measures that will be used to control soil erosion, runoff, and sediment. In this field guide the terms Stormwater Pollution Prevention Plan (SWPPP) and SESC Plan are synonymous. A SESC Plan is required for construction projects of 1 acre or more under the RIPDES stormwater Construction General Permit. In addition, for those projects subject to the RI Stormwater Design and Installation Standards Manual a SESC Plan is also required per Minimum Standard 10, regardless of site size. A SWPPP addresses non-point source stormwater discharges via erosion prevention and sediment controls.

A SESC Plan:

- Includes a **site plan** for the project that shows the drainage patterns and slopes, areas of disturbance (cuts/fills, grading), location and details of all erosion and sediment controls, location of surface waters and wetlands and the location of stormwater drainage control points,
- Identifies potential **sources of stormwater pollution**,
- Describes **measures to reduce pollutants** in stormwater discharges,
- Describes procedures to **control erosion and sediment**,
- Is a **working document** that must be:
 - Readily available on-site and
 - Updated if/as site conditions change. **Note that some changes may require RIDEM or CRMC review and written approval.** Prior to modifying the SESC Plan, the contractor should consult with the RIDEM or the CRMC.

For more detailed information, please refer to the RI Model Soil Erosion and Sediment Control Plan Template which is available at the following website: <http://www.dem.ri.gov/programs/water/permits/ripdes/stormwater/stormwater-manual.php>

Control Measure Installation, Inspection, and Maintenance Requirements

Installation Requirements

Complete the installation of temporary erosion, runoff, sediment, and pollution prevention control measures by the time each phase of earth-disturbance has begun. All stormwater control measures must be installed in accordance with good engineering judgement, including applicable design specifications. Installation techniques and maintenance requirements may be found in this Field Guide, the RI SESC Handbook, or in manufacturer specifications. Any departures from such specifications must be described and demonstrated to reflect good engineering judgment.

Inspection Requirements

Minimum Frequency

Each of the following areas must be inspected by or under the supervision of the Owner and Operator at least once every seven (7) calendar days and within twenty-four (24) hours after any storm event which generates at least 0.25 inches of rainfall per twenty-four (24) hour period and/or after a significant amount of runoff:

- All areas that have been cleared, graded, or excavated and that have not yet completed stabilization;
- All stormwater erosion, runoff, and sediment control measures (including pollution prevention control measures) installed at the site;
- Construction material, unstabilized soil stockpiles, waste, borrow, or equipment storage, and maintenance areas that are exposed to precipitation;
- All areas where stormwater typically flows within the site, including temporary drainage ways designed to divert, convey, and/or treat stormwater;
- All points of discharge from the site;
- All locations where temporary or permanent stabilization control measures have been implemented; and
- All locations where vehicles enter or exit the site.

Qualified Personnel

The owner and operator are responsible for designating personnel to conduct inspections and for ensuring that the personnel who are responsible for conducting inspections are “qualified” to do so. A “qualified person” is a person knowledgeable in the principles and practices of erosion, runoff, sediment, and pollution prevention control, who possesses the skills to assess conditions at the construction site that could impact stormwater quality, and the skills to assess the effectiveness of any stormwater control measures selected and installed at the construction site.

Recordkeeping Requirements – All records of inspections, including records of maintenance and corrective actions must be maintained with the SESC Plan. Inspection records must include the date and time of the inspection, and the inspector's name, signature, and contact information.

Reductions in Inspection Frequency – If earth-disturbing activities are suspended due to frozen conditions, inspections may be reduced to a frequency of once per month. The owner and operator must document the beginning and ending dates of these periods in the SESC Plan.

Maintenance Requirements

Site owners and operators must ensure that all erosion, runoff, sediment, and pollution prevention control measures remain in effective operating condition and are protected from activities that would reduce their effectiveness. After conducting an inspection if the designated site inspector finds a problem (i.e. erosion, runoff, sediment or pollution prevention control measures require replacement, repair, or maintenance), the owner and operator must ensure that the necessary repairs or modifications are made in accordance with the following:

- Initiate work to fix the problem immediately after discovering the problem, and complete such work by the close of the next workday, if the problem does not require significant repair or replacement, or if the problem can be corrected through routine maintenance.
- When installation of a new control or significant repair is needed, site owners and operators must ensure that the new or modified control measure is installed and made operational by no later than seven (7) calendar days from the time of discovery, where feasible. If it is infeasible to complete the installation or repair within seven(7) calendar days, the reasons why it is infeasible must be documented in the SESC Plan along with the schedule for installing the stormwater control(s) and making it operational as soon as practicable after the 7-day timeframe.
- If corrective actions are required the site owner and operator must ensure that all corrective actions are documented on the inspection report in which the problem was first discovered. Corrective actions shall be documented, signed, and dated by the site operator once all necessary repairs have been completed.

Control Measures: Doing it Right!

Every construction project, from a simple back porch addition, to a large-scale subdivision, needs to implement Control Measures to minimize disturbance and control runoff, erosion, and sedimentation. Yes, every project should:

1. **Preserve as much vegetation** as is feasible,
2. Control **runoff** and minimize erosive potential
3. Control **erosion** and stabilize the soil and
4. Control **sediment** and keep sediment on site.

Following are summaries of each of these categories of Control Measures.

Primary Control Measures: Minimizing Disturbance

Preserving vegetation and vegetated buffers is the best and least expensive way to maintain a construction site as stable. Vegetation holds soil in place, holds moisture, and helps stormwater infiltrate, all key to preventing erosion and controlling sediment movement.

Construction phasing or sequencing is critical to minimize land disturbance at any one time. Phasing plans should:

- Limit the amount of exposed or unstable soil,
- Limit the duration of exposure to the weather,
- Protect sensitive resources such as rare and endangered species, wildlife and fishery habitats and/or protecting different areas during different critical seasons, and
- Protect highly erodible soils, especially in situations involving clearing or grubbing (removing stumps) and/or during times of high water table or wet conditions.

On a large site, a project should be divided into phases, allowing disturbance of only small portions of the site at any one time to prevent and control erosion. Phases should be clearly illustrated on plans, in detailed narratives, and with field flags or stakes. Phases should ensure that grading and grubbing are done only where and when necessary.

Runoff Control: Minimizing Erosion Potential

Runoff is the stormwater that flows over and off a site. It may cause flooding or increased erosion potential, or it may be laden with sediment and toxicants.

Runoff control includes a variety of practices, devices and products designed to minimize runoff potential and infiltrate, collect, convey or filter what runoff exists prior to its release on or off site.

Reducing impervious areas and increasing pervious areas and infiltration is the best place to start. Runoff controls can be effectively placed throughout a construction site, around the perimeter and at stormwater outlets.

Erosion Control: Stabilizing Soil Surfaces

Erosion is the process in which wind and rain detach soil and transport it down-slope.

Erosion control includes a variety of practices, devices and products that protect exposed ground from erosive forces such as rain and wind, or strengthen slopes that would otherwise be unstable. If erosion can be prevented or controlled, sediment will remain in place and not travel to adjacent environments, including wetlands and waterways. ***Proper erosion control precludes the need for costly sediment control.***

Sediment Control: Keeping Sediment On-Site

Sediment is the soil particles that have been washed away from disturbed land and are being transported by stormwater or waterways. Some sediment is going to be transported. This chapter addresses methods to trap and keep that sediment on site.

Sediment control includes a variety of practices, devices and products designed to trap sediment on-site or to collect or filter it from stormwater runoff. Sediment controls can be effectively placed throughout a construction site, around the perimeter, along the contours, at grade changes and/or at stormwater outlets.

Selecting Control Measures

There are so many Control Measures available. How do you know what should be employed in any given situation?

To choose the correct Control Measure for a given situation, follow the three steps below:

1. Identify the ***primary need*** (runoff control to minimize erosion potential, erosion control to stabilize the soils, or sediment control to keep mobile sediment on site).
2. Identify the ***type of protection*** that will best match the characteristics of the site, the functions of the wetland resource areas and the project. (e.g., a sediment barrier)
3. Identify the ***specific Control Measure*** that will best meet the immediate and long-term needs of the site. Each Control Measure is described in further detail in this field guide.

Minimizing Disturbed Area: Preserving Soils & Vegetation



Description

Maintain maximum areas of mature vegetation and undisturbed soils on a construction site and at the individual lot level, through the reduction of site clearing, grubbing, and grading, and the maximization of vegetation preservation. This is accomplished through the following:

- Careful site planning addressing: sensitive areas; proposed roads, utilities and other infrastructure; building locations and elevations (to best fit the existing topography); and landscape plans.
- Construction phasing and sequencing.
- Careful delineation of limits of work.

Inspection, Maintenance, and Removal Requirements

- Routinely inspect no-disturbance areas and protected areas to ensure that they are flagged, protected, and healthy.
- Re-delineate and protect as necessary.
- Remove measures only once all construction has ceased and the entire site is stable.

Troubleshooting Tips

Condition	Common Solution
Vehicles and equipment run into or over vegetation that is to be preserved.	Clearly mark areas of preservation, and instruct workers to honor those areas.
Existing vegetation dies from lack of watering.	Maintain existing irrigation systems and ensure that they function properly.
Preserved trees are damaged.	Keep equipment and vehicles away from trees to prevent trunk and root damage. Severely damaged trees should be attended to by an arborist.
ESAs or areas where construction is not to occur or can occur at a later date are not delineated for protection.	Verify vegetation that requires preservation. Stop work if necessary. Delineate area as needed.

Protecting Vegetated Buffers



Description

Preserving and enhancing an area of existing and established trees, shrubs, vines, grass and other perennial plants adjacent to a body of water or other sensitive area.

Inspection and Maintenance

- Check for stockpiles, vehicular parking and excessive foot or vehicular traffic within the area of protected vegetation.
- Inspect locations for any sediment discharges into the protected areas.
- Restore areas disturbed, disrupted or damaged by the Contractors to pre-construction conditions, or better, at no additional expense to the contract.
- Prune all tree branches broken, severed or damaged during construction. Cut all limbs and branches, one-half inch, or greater, in diameter, at the base of the damage and flush with the adjacent limb or tree trunk.
- Smoothly cut all roots (1 inch or greater in diameter) cut, broken, or severed during construction perpendicular to the root.

Troubleshooting Tips

Condition	Common Solution
Damaged vegetation	Replace with similar species. Check with designer for appropriate replacements.
Cuts, skins, scrapes or bruises to the bark of the vegetation	Trim any cuts, scrapes or bruises to the bark and utilize local nursery accepted procedures to seal damaged bark.
Roots exposed during excavation	Cover with moist earth and/or backfill immediately to prevent roots from drying.
Sediment has covered one-third of the length of the buffer	Remove sediment from the vegetated buffer
Clean sediment discharges from the vegetated buffer	Implement other BMP(s) to stabilize until buffer is restored

Good & Bad Practices

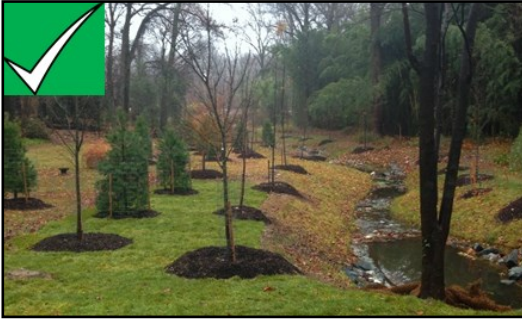

- * Well planted vegetative buffer.
- * Adds canopy and root mass to protect banks of stream and filter pollutants.



- * Herbaceous cover and highly maintained buffer reduces plant diversity and allows bank to be eroded during storm events.

Limit of Work and Site Access Control



Description

A physical barrier that restricts site access to designated entrances and exits, delineates construction site boundaries, and keeps construction out of sensitive areas such as natural areas to be preserved as open space, wetlands and riparian areas.

Orange Safety or Construction Fence Installation

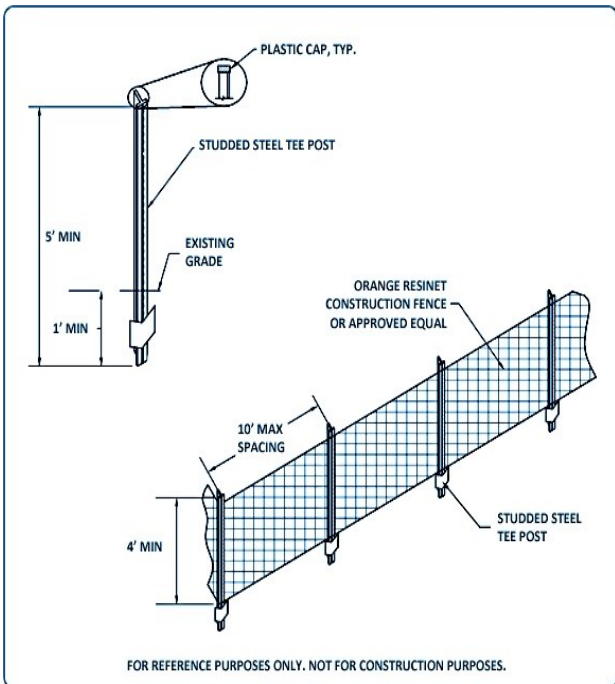

Installation

- Studded steel t-posts shall be used, spaced no more than 10 ft. apart, and fitted with plastic caps for safety.
- Fencing material shall be securely fastened to the top, middle, and bottom of each post.

Inspection, Maintenance, and Removal Requirements

- Frequent observations and maintenance are necessary to maintain controls in effective operating condition.
- Inspect controls each workday and maintain them in effective operating condition.
- Maintenance of controls should be proactive, not reactive.
- Where controls have been damage, sagged, ripped, or failed, repair or replacement should be initiated upon discovery of the failure (and always within 24 hours of a storm that causes surface erosion).
- Inspections and corrective measures should be documented thoroughly.
- Controls are to remain in place until the up-gradient disturbed area is stabilized and approved by the local jurisdiction.
- When controls are removed, all disturbed areas associated with the installation, maintenance, and/or removal of the barrier/structure shall be covered with topsoil, seeded, mulched, or otherwise stabilized as approved by the local jurisdiction.

Troubleshooting Tips

Condition	Common Solution
Controls have been damaged, sagged, ripped, or failed	Repair, or replacement, should be initiated upon discovery of the failure, and always within 24 hours of a storm that potentially will cause surface erosion.

Good & Bad Practices



- * Proper access control onto and off construction site protects existing and natural vegetation and reduces compaction of soils



- * Improper access control allows for failure of control measures and sediments to leave site.

Tree Protection



Description

The protection of desirable trees (individual specimens or groups) from mechanical and other injury during construction.

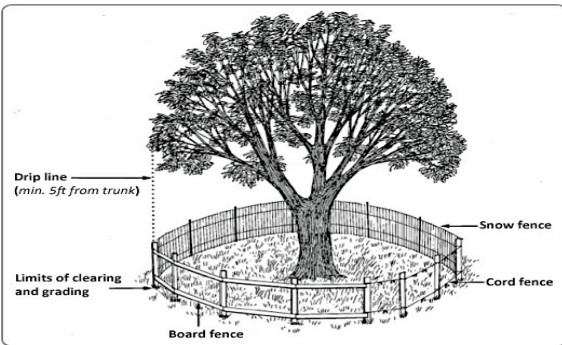

Installation

- The limits of clearing should be located outside the drip line of any tree to be retained, and in no case closer than five feet to the trunk of such a tree.
- Marking individual trees and stands of trees to be retained should be visibly marked with a bright colored surveyor's ribbon or flagging applied in a band circling the tree at a height visible to equipment operators, or with other suitable barriers to construction equipment, such as brightly colored "snow fence".
- No toxic materials should be stored within 100 feet of the drip line of any trees to be retained.
- Trees to be retained within 40 feet of a proposed building or earth moving activities should be protected by fencing.

- Fencing should be highly visible, of sturdy construction and at least 3 feet high. Fences may be snow fence, board fence, synthetic fabric fence, plastic fence or similar materials.
- Trunk Armoring may be used, with burlap wrapping and 2-inch studs wired vertically no more than two inches apart to a height of five feet encircling the trunk. The root zone within the drip line will still require protection with this alternative.

Trunk Armoring

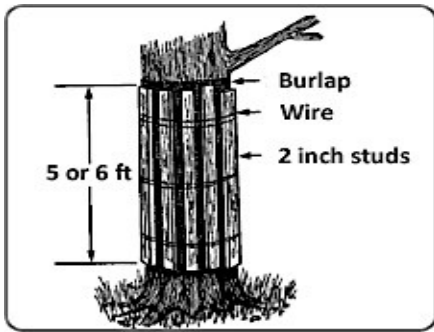

Inspection, Maintenance, and Removal Requirements

- If the soil has become compacted over the root zone of any tree, the ground should be aerated by punching small holes in it with suitable aerating equipment.
- Any damage to the crown, trunk or root system of any tree retained on the site should be repaired immediately.
- Damaged roots should immediately be cut off cleanly inside the exposed or damaged area.
- Cut surfaces may be painted with approved tree paint.
- Moist peat moss, burlap or topsoil should be spread over the exposed area.
- All tree limbs damaged during construction or removed for any other reason should be cut off above the collar at the preceding branch junction.

→Larger limbs may require several cuts to safely remove the damaged limb without damaging the trunk.

→Remove all protective materials once final site stabilization is complete and all heavy equipment is removed from the vicinity of the protected tree.

Troubleshooting Tips

Condition	Common Solution
Protected area not clearly marked.	Use construction fencing and signage.
Sediment discharges into protected area.	Remove deposited sediment and install proper BMPs.
Large tree root cut or exposed.	Extend fencing beyond drip line to protect roots. Remove the ends of damages roots with a smooth cut. Cover exposed roots with soil.
Soil compacted over roots.	Aerate soil by punching holes 12 inches deep, 18 inches apart.

Dust Control



Description

Dust control involves a variety of measures and technologies to reduce or prevent the movement of dust from construction sites, material stockpiles and other unvegetated areas to sensitive areas. Different measures include, but are not limited to: mulch and vegetation; board, burlap, or snow fence barriers erected at right angles to prevailing wind; or liquid/chemical treatments such as water, tackifiers, calcium chloride and polymers.

Inspection and Maintenance

- Treatments using water, polymers, tackifiers, etc. need to be maintained and repeated as required by wet and dry conditions and product longevity.
- Areas with dust control measures in place should be inspected daily.
- Physical structures such as barriers and fences should be regularly inspected and repaired as needed.

Troubleshooting Tip

Condition	Common Solution
Excessive dust leaves the site.	Increase frequency of water application or other controls. Install buffers or barriers near roadways.
Vehicles kick up dust.	Water more frequently. Limit vehicle speeds. Stabilize the roadway.
Watering for dust control causes erosion.	Reduce water pressure on the water truck. Check watering equipment to ensure that it has a positive shutoff. Water less frequently.
Sprayed areas are ineffective at limiting dust.	Re-spray areas and ensure that the application rate is proper or stabilize site using other practices.

Good & Bad Practices

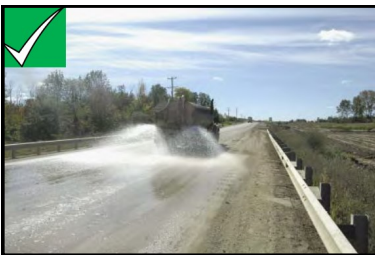

- * Good dust control.
- * Even distribution of water
- * Controlled application to avoid vegetated areas.

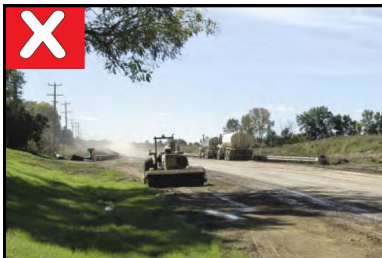

- * Poor dust control.
- * Site has dust blowing from equipment travel
- * Water application not present or inadequate.

Spill Prevention and Control Plans



Description

Spill Prevention and Control Plans (SPCPs) clearly state practices to stop the source of a spill, contain the spill, clean up the spill, dispose of contaminated materials, and train personnel to prevent and control future spills.

Inspection and Maintenance

- Spills and leaks will be avoided through frequent inspection of equipment and material storage areas.
- Heavy equipment and other vehicles will be routinely inspected for leaks and repaired as necessary.
- Material storage areas will be routinely inspected for leaky containers, open containers, or improper storage techniques that may lead to spills or leaks.
- Appropriate cleanup procedures and supplies will be available on-site.
- Spills will be cleaned up immediately and following proper response procedures and in accordance with any applicable regulatory requirements.
- At no time will spills be cleaned and flushed down storm drains or in to any environmentally sensitive area (e.g., stream, pond, or wetland).
- Update the SPCP regularly to accommodate any changes in the site, procedures, or responsible staff.
- Conduct regular inspections in areas where spills might occur to ensure that procedures are posted and cleanup equipment is readily available.

Troubleshooting Tips

Condition	Common solutions
Material spills occur on a permeable surface.	Contain spread of spill with an earthen dike. Dig up and properly dispose of contaminated soil.
Material spills occur on an impermeable surface.	Use dry absorbent materials to encircle and contain the spill. Place clean-up materials in a drum and dispose of properly.
The spill exceeds the capacity of spill cleanup materials on site.	Contain spill. Obtain enough spill clean-up materials to completely clean up the spill. Contact Caltrans Maintenance. Store additional spill clean-up materials as necessary.
Spilled material encroaches onto travel way.	Contact Caltrans Maintenance. Use additional spill clean-up materials as necessary and replenish these materials in adequate quantity for future use.

Stockpile and Staging Area Management



Description

Procedures and measures to manage stockpiles of topsoil and other types materials, including, but not limited to: paving materials such as Portland cement concrete (PCC) rubble, asphalt concrete (AC), asphalt concrete rubble, aggregate base, aggregate sub base or pre-mixed aggregate, asphalt minder (so called “cold mix” asphalt), and pressure treated wood.

Inspection, Maintenance, and Removal Requirements

- Inspect and verify that activity–based measures are in place prior to the commencement of associated activities.
- While activities associated with the measure are under way, inspect weekly during the rainy season and of two-week intervals in the non-rainy season to verify continued measure implementation
- Repair and/or replace perimeter controls and covers as needed to keep them functioning properly.
- After the stockpile has been removed, the site should be graded and permanently stabilized.

Troubleshooting Tips

Condition	Common Solution
Stockpile eroded.	Cover stockpile with plastic sheeting or spray with a soil binder. Protect with a temporary sediment barrier around the perimeter of the stockpile.
Stockpile located in drainage path.	Remove stockpile from the drainage path or protect with a dike, swale, or temporary diversion device.
Stormwater run-on erodes stockpile.	Protect the stockpile by using temporary sediment barriers such as berms, ditches, or silt fencing.
Wind causes erosion and-or blowing dust.	Cover stockpile or spray with a soil binder. Use a water application to suppress dust. Install wind barrier.
Plastic sheeting separates along the seams.	Overlap edges by 12 to 24 inches, tape the entire length or anchor with sandbags along seam.
Plastic sheeting tears and separates.	Replace damaged sections.
Plastic sheet is blown or displaced by winds.	Anchor with sandbags or other suitable tethered anchoring system, space on 10 foot grids.

Good & Bad Practices



- * Note that tarps are being used to cover unused materials and materials are on pallets.



- * There are no temporary perimeter sediment barriers such as erosion logs, silt fence or compacted berms to protect this stockpile from storm-water runoff.
- * Surface treatment on the stockpile may be necessary if left exposed.

Street Sweeping



Description

Street sweeping and vacuuming include use of self-propelled and walk-behind equipment to remove sediment from roadways in construction sites, road construction sites, and other paved areas where sediment has been deposited.

Inspection and Maintenance

- Inspect and sweep prior to rain events.
- Properly disposed of collected street sweeping wastes. Street sweeping material often includes sand, salt, leaves, and debris removed from roads. Often the collected sweepings contain pollutants and must be tested prior to disposal to determine if the material is hazardous.
- Constructions Site Owners and Operators should adhere to all federal and state regulations that apply to the disposal and reuse of sweepings.
- Federal and state regulations may allow the reuse of sweepings for general fill, parks, road shoulders and other applications as long as the material is not a threat to surface waters.
- Prior to reuse, trash, leaves, and other debris from sweepings should be removed by screening or other methods (MPCA, 1997).
- Trash and debris removed should be disposed of by recycling or sent to a landfill (MPCA, 1997).
- Repeat application of sweeping control measures when fugitive dust becomes evident.

Troubleshooting Tips

Condition	Common Solution
Sediment tracking is excessive.	Install a stabilized construction entrance/exit at egress point.
Sweeper is not picking up sediment.	Adjust sweeper brooms to maximize efficiency of sweeping operations.
Sweeping causes excessive dust.	Use a sweeper with a vacuum attachment. Use sweeper with water spray device to reduce dust. Never use kick brooms or sweeper attachments.
Sediment is being tracked from many areas of the job site.	Limit egress and ingress locations and instruct personnel to use designated centralized entrance/outlet locations.

Good & Bad Practices



- * Excellent use of a sweeper to clean up a construction site.



- * The dirt that is being blown on this street can do more harm than good.

Waste Management



Description

On-site management of trash disposal, recycling, proper material handling, and spill prevention and cleanup measures, proper location of refuse piles, covering materials that might be displaced by rainfall or stormwater runoff, and preventing spills and leaks from hazardous materials.

Inspection and Maintenance

- All waste containers will be covered to avoid contact with wind and precipitation.
- Waste collection will be scheduled frequently enough to prevent containers from overflowing.
- All construction site wastes will be collected, removed, and disposed of in accordance with applicable regulatory requirements and only at authorized disposal sites.
- Inspect storage and use areas and identify containers or equipment that could malfunction and cause leaks or spills.
- Check equipment and containers for leaks, corrosion, support or foundation failure, or other signs of deterioration, and test them for soundness.
- Immediately repair or replace any that are found to be defective.

Troubleshooting Tips

Condition	Common Solution
Materials located throughout construction site.	Designate storage area away from water bodies and storm drains. When practical do not stockpile materials on site. Bring to the site only what will be used within a reasonable timeframe.
Litter and trash found on construction site or in the storm drain system.	Provide dumpsters or other containers. Collect trash and dispose of properly.
Overflowing dumpsters.	Arrange for waste collection before containers overflow.
Leaking dumpsters.	Contact dumpster provider and request new dumpster. Close lid or provide cover.
Hazardous chemicals, drums, or bagged materials are stored directly on the ground.	Place material on a pallet and when possible, under cover and in secondary container.
Hazardous waste containers are not labeled.	Re-label items with an original label or remove substances from the site.
Leaking hazardous materials containers.	Contain spill immediately. Damaged or leaking containers should be placed in over-pack drums or secondary containment. Properly dispose of waste and any contaminated soil as hazardous waste.
Portable toilet tipped over.	Place toilet on level surface and out of drainage paths or traffic areas. Stake down.
Portable toilets leaks.	Repair or replace.

Good & Bad Practices



* Covered area away from water-course.



* Materials are placed directly on soil without spill/leak protection.

Concrete Washout



Description

A designated washout area with signs to provide careful oversight to manage concrete washwater that is generated from washing out ready-mix trucks, drums and pumps; it also includes the water from rinsing off chutes, equipment (wheelbarrows and hand tools), and concrete truck exteriors to prevent improper dumping of concrete wash water.

Installation

→Locate washout area at least 50 feet from sensitive areas such as storm drains, open ditches, or water bodies, including wetlands.

Inspection

→Inspect and verify that concrete washout SESC measures are in place prior to the commencement of concrete work.

→During periods of concrete work, inspect daily to verify continued performance.

→Check overall condition and performance.

→Check remaining capacity (% full).

→If using self-installed washout facilities, verify plastic liners are intact and sidewalls are not damaged.

→If using prefabricated containers, check for leaks.

Maintenance

- Washout facilities shall be maintained to provide adequate holding capacity with a minimum freeboard of 12 inches.
- Washout facilities must be cleaned, or new facilities must be constructed and ready for use once the washout is 75% full.
- If the washout is nearing capacity, vacuum and dispose of the waste material in an approved manner.
- Do not discharge liquid or slurry to waterways, storm drains or directly onto ground.
- Do not use sanitary sewer without local approval.
- Place a secure, non-collapsing, non-water collecting cover over the concrete washout facility prior to predicted wet weather to prevent accumulation and overflow of precipitation.
- Remove and dispose of hardened concrete and return the structure to a functional condition.
- Concrete may be reused onsite or hauled away for disposal or recycling.
- When materials from the self-installed concrete washout are removed, build a new structure; or, if the previous structure is still intact, inspect for signs of weakening or damage, and make any necessary repairs.
- Re-line the structure with new plastic after each cleaning.
- Materials used to construct temporary concrete washout facilities shall be removed from the site of the work and disposed of or recycled.
- Holes, depressions or other ground disturbance caused by the removal of the temporary concrete washout facilities shall be backfilled, repaired, and stabilized to prevent erosion.

Removal

- When temporary concrete washout facilities are no longer required for the work, the hardened concrete, slurries and liquids shall be removed and properly disposed of.

Troubleshooting Tips

Condition	Common Solution
Washout overflows.	Pump or siphon off excess liquids and properly dispose in a manner that does not violate groundwater or surface water quality standards. If necessary, discontinue using washout and construct new facility to contain anticipated washout operations.
Drivers not using washout area.	Place sign at washouts and instruct drivers of the washout locations. Educate drivers and other concrete company personnel.

Good & Bad Practices



- * Properly identified concrete washout area.
- * Reinforced concrete washout with ample storage.



- * Improperly located concrete washout.
- * Undersized and non-reinforced structure.

Vehicle Fueling, Maintenance and Washing



Description

Designated areas for equipment fueling, maintenance and storage of overnight storage of construction equipment and materials used for vehicle fueling, maintenance and washing.

Installation

- Vehicle fueling, maintenance and/or washing will occur off-site, or in designated areas.
- Designated areas will not be located within any of the constraint areas located on the “Constraint Map” in the SESC Plan and will be approved by the project engineer or responsible person.
- Areas will be clearly designated, and berms, sandbags, or other barriers will be used around the perimeter of the maintenance area to prevent stormwater contamination.
- Make available absorbent spill cleanup materials and spill kits in fueling areas and on fueling trucks.

Inspection and Maintenance

- Inspect vehicles, equipment, and storage containers daily for leaks.
- Repair leaks immediately or remove problem vehicles or equipment from the project site.
- Keep ample supplies of spill cleanup materials onsite.
- Clean up spills and dispose of cleanup materials immediately.

→Disposal of all used oil, antifreeze, solvents and other automotive-related chemicals will be according to applicable regulations; at no time will any material be washed down the storm drain or in to any environmentally sensitive area.

→Maintenance of vehicle wash areas is minimal, usually involving repairs to berms and drainage to the sanitary sewer system.

Troubleshooting Tips

Condition	Common Solution
Vehicles and equipment leak fuel.	Do not top off vehicle fuel tanks. Repair immediately or remove problem vehicles or equipment from the project site.
Fueling tanks are not stored in temporary containment facilities.	Place fuel tanks in bermed temporary containment facility.
Fuel spills on ground.	Use absorbent material to clean up spill and dispose of used clean-up materials properly. Never hose down or bury spills. If fuel spills on soil, clean up contaminated soil and dispose of properly.
Used oil, filters, and vehicle fluids are stored onsite.	Place used materials in a temporary containment facility and schedule regular pickups to dispose of these materials.
Vehicles and equipment leak fluids onto the ground.	Clean up spills on pavement with absorbent. Clean up contaminated soil. Dispose of clean-up waste properly. Place drip pans or absorbent materials under parked vehicles and equipment. Repair equipment and vehicles immediately or remove from the project site.

More Troubleshooting Tips

Run-on flows onto the maintenance area.	Construct a berm, dike, or temporary diversion structure around maintenance facility.
Wash water leaves the site.	Contain wash water in a bermed area and dispose of water outside the right-of-way.
Washing occurs on a pervious surface.	Contain water in a concrete or paved bermed area. Place a sump in the wash area and transfer wash water to sanitary sewer system or temporary sediment trap. Never discharge wash water to storm drains or receiving waters.
Vehicle fluids are spilled onto the wash-rack.	Clean up spilled material and dispose of properly. Contain contaminated water and dispose of properly. Do not allow spilled material to flow to storm drain system.

Mulching



Description

Application of suitable materials, (plant residues or other suitable materials) to the soil surface to provide short-term, medium-term, or permanent soil protection.

Inspection and Maintenance

Temporary Soil Protection

- Inspect temporary soil protection area at least once a week and within 24 hours of the end of a storm with a rainfall amount of 0.5 inch or greater for mulch movement and rill erosion.
- Where soil protection falls below 100%, reapply soil protection within 48 hours. Determine the cause of the failure.
 - If mulch failure was the result of wind, consider applying a tackifier or netting.
 - If mulch failure was caused by concentrating water, install additional measures to control water and sediment movement, repair erosion damage, reapply mulch with anchoring or use Temporary Erosion Control Blankets.
- Inspections should take place until work resumes.

Mulch For Seed

- Inspect mulched areas at least once a week and within 24 hours of the end of a storm with a rainfall amount of 0.5 inch or greater until the grass has germinated to determine maintenance needs.
- Where mulch has been moved or where soil erosion has occurred, determine the cause of the failure.
 - If it was the result of wind, then repair erosion damage (if any), reapply mulch (and seed as needed) and consider applying a netting or tackifier.

→If mulch failure was caused by concentrating water, install additional measures to control water and sediment movement, repair erosion damage, reapply mulch and consider applying a netting or tackifier or use the Temporary Erosion Control Blanket measure.

→Once grass has germinated, inspections should continue as required by Temporary Seeding and Permanent Seeding.

Landscape Mulch

→Inspect 2 to 3 months after the first application and then once a year for mulch movement, rill erosion and decay.

→Where mulch has been moved by concentrated waters, install additional measures to control water and sediment movement, repair erosion damage, remove any unwanted vegetation and reapply mulch.

→If mulch has decayed exposing underlying soil, repair any erosion damage, remove any unwanted vegetation and reapply mulch.

Troubleshooting Tips

Condition	Common Solution
Coverage is inadequate.	Fill in or remove rills and re-apply where necessary following recommended application rates.
Portions of the mulch have been disturbed.	Keep workers and equipment off mulched areas and repair damaged areas. Using fencing if needed.
Excessive water flows across stabilized surface.	Utilize additional BMPs to disperse/minimize flow on stabilized areas and/or reduce slope lengths.
Mulch blows away.	Anchor straw mulch in place by applying a tackifier, crimping, punching, or track walking. May need to use a different BMP.

Good & Bad Practices



- * A good *Straw Mulch* application will ensure evenly distributed, uniform coverage.
- * Crimping must be executed along the grade contour.



- * Correct application and installation methods should prevent fugitive Straw Mulch from migrating off-site.

Soil Preparation and Topsoiling



Description

The spreading of topsoil of suitable quality and quantity over an area that has been cut, filled, or graded so that the area may be stabilized by vegetation.

Inspection

Inspection may be made by qualified individuals who submit signed certification that the approved SMP had been implemented.

Preferred Inspection Schedule and Tasks

- **Pre-Grading Inspection:** Prior to the commencement of site work, contact the Applicant (Owner/Operator) to provide an inspection to verify the delineation and protection of native soils and vegetation to remain undisturbed per the SMP, and to verify the proposed location for topsoil and material stockpiling.
- **Grading Progress Inspection:** Prior to the placement of soil amendments, contact the Applicant (Owner/Operator) to provide an inspection to verify that specified erosion control methods have been implemented, the location of stockpiled soil and materials follow the Soil Management Plan, and that subgrades are consistent with the Soil Management Plan.
- **Post-Construction Inspection:** Prior to planting, contact the Applicant (Owner/Operator) to provide an inspection to verify that the placement of amendments and soil preparation is consistent with the SMP. Verify appropriate soil compaction, scarification and amendment incorporation by digging at least one 12 inch deep test hole per acre for turf and at least one per acre for planting beds using a garden spade driven solely by inspector's weight (less than 80 psi) or 10 locations per landscaped acre using a simple "rod penetrometer" (a 4 foot long 3/8th inch diameter stainless steel rod, with and a 30 degree bevel cut). Rod must penetrate to 12" depth driven solely by inspector's weight – less than 80 psi.

→At the completion of planting, contact the Applicant (Owner/Operator) to provide a review to verify that mulch has been installed as specified.

→Secondary Verification for Failing Sites: If the Applicant (Owner/Operator) determines that the installation does not meet the conditions of the approved SMP, additional testing by an independent certified soil consultant will be ordered by the Applicant (Owner/Operator).

Maintenance

Once topsoiling has been established, these areas should be protected from compaction such as from heavy equipment operation and soil loss by erosion.

Troubleshooting Tips

Condition	Common Solution
Any irregularities in the surface resulting from topsoiling or other operations	Correct to prevent the formation of depressions or water pockets.

Seeding for Temporary Vegetative Cover



Description

Establishment of temporary vegetative cover (grass and/or legumes) on soils, exposed for a period greater than one month but less than 12 months, to reduce damage from wind and/or water erosion and sedimentation until permanent stabilization is achieved.

Inspection and Maintenance

- Seeded areas should be inspected at least once per week and within 24 hours following a precipitation event with a rainfall amount of 0.25 inch or greater for erosion and seed and mulch movement.
- If wind is the cause of movement, the erosion damage should be repaired (reseed and re-mulched) and supplemented with a mulch anchor.
- If concentrated runoff is the cause of the failure, additional measures to control water and sediment movement should be installed, the erosion damage repaired, and the area reseeded with the new mulch and anchoring or use temporary Erosion Control Blanket.
- Temporary vegetative cover shall not be considered established until ground cover (approximately 80% vegetative surface cover) controls soil erosion and withstands severe weather conditions.

Troubleshooting Tips

See **Seeding for Permanent Vegetative Cover** (next measure).

Good & Bad Practices

See **Seeding for Permanent Vegetative Cover** (next measure).

Seeding for Permanent Vegetative Cover



Description

Establishment of permanent vegetative cover by seeding and mulching exposed soils with an appropriate seed mixture to facilitate long term stabilization following site preparation and topsoiling.

Inspection and Maintenance

- Lime according to a soil test or at a minimum every 2 to 3 years using a rate of one ton per acre (50 lbs per 1,000 sq. ft.).
- Where grasses predominate, fertilize if so indicated by a soil test. Customary applications are biennial broadcasts of 500 lbs of 10-6-4 (lawn fertilizer) or equivalent per acre (12.5 lbs per 1,000 sq. ft.). At least 30% of the fertilizer's available nitrogen must be in a slow releasing form.
- Where legumes predominate, fertilize according to a soil test or every three years, broadcast 300 lbs of 0-20-20 or equivalent per acre (7.5 lbs per 1,000 sq. ft.).
- Permanent vegetative cover shall not be considered established until ground cover (approximately 95% vegetative surface cover) controls soil erosion and withstands severe weather conditions.

Troubleshooting Tips:

Seeding for Temporary & Permanent Vegetative Cover

Condition	Common Solution
Seeds fail to germinate.	Verify that seed is appropriate for your area and reapply. Apply mulch to keep seeds in place and to moderate soil moisture and temperature. Temporary irrigation may be necessary.
Seeded slope fails.	Fill in rills and re-seed. Combine with erosion control blankets or mats.
Seeding is washed off slope.	Re-apply where necessary and mulch.
Grass is dying.	Provide temporary irrigation. Top-dress with compost to hold moisture and provide nutrients and heat for seeds.
Bare spots in vegetative cover.	Rake, drill, or walk in seed to ensure good ground contact. Over-seed bare areas and ensure adequate water and nutrients.

Good & Bad Practices:

Seeding for Temporary & Permanent Vegetative Cover



- * Good seeding.
- * Mixture has minimal weeds
- * Grass has merged and no bare soil exists.



- * Poor erosion control.
- * Seed growth is spotty.
- * Bare soil conditions enable erosion.

Sodding



Description:

Stabilizing fine-graded disturbed areas with the use of cut pieces of turf. Sod consists of stoloniferous or rhizomatous grasses that form a dense mat of plants, being cut at a uniform soil thickness of 0.75 inch \pm 0.25 inch) at the time of cutting, excluding the shoot growth and thatch.

Inspection and Maintenance:

- During the first week, inspect daily and if rainfall is inadequate, then water the sod as often as necessary to maintain moist soil to a depth of at least 4 inches below the sod.
- After the first week, inspect sodded area at least once a week and within 24 hours of the end of a storm with a rainfall amount of 0.25 inch or greater during the first growing season.
- Where sod has died or has been moved or where soil erosion has occurred, determine if the failure was caused by inadequate irrigation, poorly prepared surface, improper anchoring, excessive sedimentation or excessive flows.
- If the failure was caused by concentrated flow, check water velocities and duration to ensure it does not exceed 5 feet per second (fps) or duration greater than 1 hour at or near 5 fps. Install additional measures to control water and sediment, repair erosion damage, and reinstall sodding with anchoring.
- Be prepared to mow sod within 1 week of installation. In order to prevent “scalping” do not remove more than 1/3 of the grass leaf at any one cutting.
- For liming and fertilization, follow soil test recommendations when possible.

Troubleshooting

Condition	Common Solution
Planting too deep	To determine the correct size hole for your plant, lay a shovel handle across the top of the root ball. Then measure from the bottom of the root ball to the shovel handle; the measurement is the depth of the hole you should dig
Root-bound stock where roots confined by burlap or pots	Remove pots and baskets without disturbing the root ball. Plastic burlap should be removed, but burlap made of natural fibers can be left on the root ball if the sides are pulled down as far as possible. If you see a mass of swirling roots, cut through the mass to allow the roots to spread out rather than continuing to encircle the base of the plant. Don't allow any portion of the burlap to remain above ground, as the fabric will wick moisture out of the planting hole
Plants are leaning or not 'sitting' straight.	When backfilling the hole, use the same soil you removed. Resist the urge to amend the soil, an old practice that is no longer recommended. Fill the hole two-thirds of the way to the top, then add water to settle the soil before you fill the remainder of the hole
Plants dry out quickly.	Hold the tree or shrub upright while firming the soil around the base with your foot. Leave a saucer-shape basin of soil at the base of the plant to collect water. Top the soil off with 3-4 inches of seasoned wood chips or shredded bark mulch. Cover a wide area around the tree base to reduce competition from weeds and grass and to conserve moisture, but don't allow the mulch to pile up against the trunk. During the first growing season, water the tree or shrub every seven to 10 days if rainfall is lacking

Good & Bad Practices



- * Lay sod on well prepared, non-compacted topsoil, with alternating joints.



- * *Soil not prepared well, joints not tight and allowed to dry out sod edges.*

Landscape Planting



Description:

Planting trees, shrubs, or groundcovers for permanent stabilization of disturbed areas that have been properly prepared and topsoiled.

Inspection:

- Inspect plants until they are established or at least monthly for 1 year following planting, and more frequently during hot dry periods for mulch adequacy, soil moisture and general plant condition.
- Larger plants, especially burlap balled trees which have lost a significant amount of their root systems upon transplanting will need the most attention during the initial establishment period.

Mulch and Water: General Guidelines

- Apply additional landscape mulch around landscape plants as needed to keep soil covered and to inhibit weed growth.
- Water plants during hot dry periods when soil around the plants begins to dry out.
- For successful establishment of summer plantings, adequate watering during the balance of the summer and into the fall is especially important.
- New plantings in Rhode Island should receive at least 1 inch of rain per week.

Insect/Disease Control: General Guidelines

- When a problem occurs, positive identification of the host, and then of the insect or disease problem is vital to successfully resolving the problem.
- The Rhode Island Cooperative Extension or a state licensed arborist can help identify insect and disease problems and suggest solutions.

Maintenance

Trees

- Young trees should receive one inch of water each week for the first two years after planting. When rain does not supply this need, the tree should be watered deeply but not more often than once per week.
- Transplanted trees should be re-fertilized annually until the tree is established.
- Some simple methods to supply fertilizer to trees are tree food spikes and holes bored around the tree drip line and filled with fertilizer.
- The recommended fertilizer formula is 5-10-10; follow the manufacturer's recommendations for application rate.
- Prune to remove only dead or damaged limbs on newly planted trees unless an arborist has recommended otherwise.
- For new roots to form from plants grown in containers, top pruning should be delayed for at least a year. Ideally, newly planted trees should not be pruned until after their third year, and then only to remove dead and weak branches, and to train the tree's future growth.

Shrubs

- Shrubs should be properly pruned, given adequate water and fertilized annually until established. Simple methods of fertilization are recommended.
- Maintain the mulch cover or turf cover surrounding the shrubs.

Ground Covers and Vines

- Most ground covers need once-a-year trimming to promote growth.
- Maintain mulch cover with additions of mulch where needed.
- Fertilize annually as described above.

Troubleshooting Tips

Troubleshooting Tips

Condition	Common Solution
Planting too deep	To determine the correct size hole for your plant, lay a shovel handle across the top of the root ball. Then measure from the bottom of the root ball to the shovel handle; the measurement is the depth of the hole you should dig.
Root-bound stock where roots confined by burlap or pots	Remove pots and baskets without disturbing the root ball. Plastic burlap should be removed, but burlap made of natural fibers can be left on the root ball if the sides are pulled down as far as possible. If you see a mass of swirling roots, cut through the mass to allow the roots to spread out rather than continuing to encircle the base of the plant. Don't allow any portion of the burlap to remain above ground, as the fabric will wick moisture out of the planting hole.
Plants are leaning or not 'sitting' straight.	When backfilling the hole, use the same soil you removed. Resist the urge to amend the soil, an old practice that is no longer recommended. Fill the hole two-thirds of the way to the top, then add water to settle the soil before you fill the remainder of the hole.
Plants dry out quickly.	Hold the tree or shrub upright while firming the soil around the base with your foot. Leave a saucer-shaped basin of soil at the base of the plant to collect water. Top the soil off with 3-4 inches of seasoned wood chips or shredded bark mulch. Cover a wide area around the tree base to reduce competition from weeds and grass and to conserve moisture, but don't allow the mulch to pile up against the trunk. During the first growing season, water the tree or shrub every seven to 10 days if rainfall is lacking.

Good & Bad Practices



* This tree is being planted at a proper depth.



* This tree was planted too deep and will eventually die from either rot or not enough air to the root ball.

Retaining Walls



Description:

Retaining walls create vertical or near vertical walls to hold back (retain) material. They may be made of railroad ties, gabions, mortared block or stone, natural stone, precast cellular blocks, modular retaining wall blocks, cast-in-place reinforced concrete and prefabricated materials.

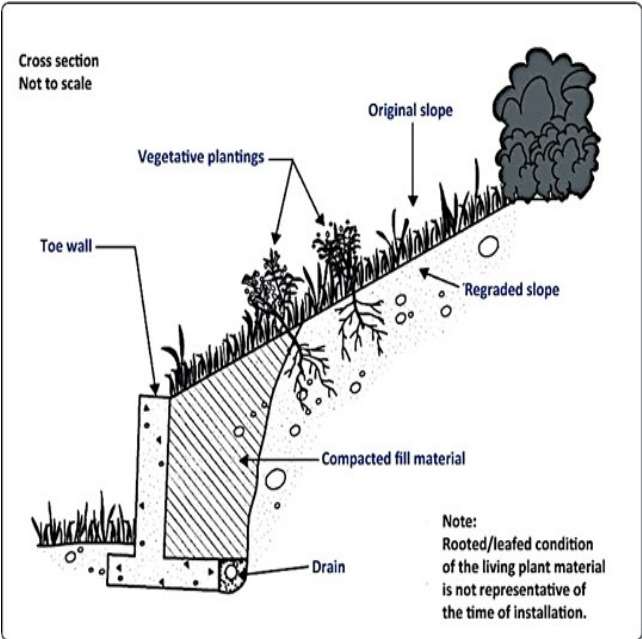

Inspection and Maintenance:

- Inspection should be comprehensive during the construction process and the wall should also be thoroughly inspected upon completion.
- Once in place, a retaining wall should require little maintenance, but should be inspected annually for signs of tipping, clogged drains, or soil subsidence. If such conditions exist, they should be corrected immediately.
- Vegetated walls will require maintenance.

Retaining Wall Failure

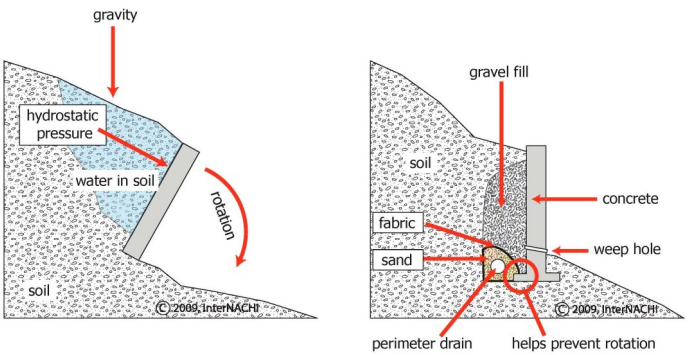

Troubleshooting

Condition	Common Solution
<p>The ground behind the retaining wall is not well drained, and water pools in the backfill.</p>	<p>The surface of the backfill needs to be properly graded, directing water away from the wall. If proper grading is not possible, install drainage channels adjacent to the wall. Another solution is to backfill a material that drains well, such as crushed rock.</p>
<p>The weight of the retaining wall causes the soil underneath to compress and/or subside.</p>	<p>Ensure the soil underneath the wall is properly compacted. If soil under wall is too weak, increase stability by adding gravel/ aggregate to the soil and compacting it.</p>

Good & Bad Practices



* Well engineered retaining wall.



* Poorly engineered retaining wall.

Slope Protection



Description

Applying materials for permanent structural protection of slopes from erosion. Materials may include, but are not limited to stone aggregates, riprap, erosion control blankets, geotextile, cellular confinement systems, mattresses (gabions and others), and articulating blocks.

Inspection, Maintenance, and Removal

Stone Slope Protection

- Inspect periodically to determine if scour has occurred beneath the stone or filter blanket or dislodged any of the stone or filter blanket materials.
- Periodic removal of woody vegetation (e.g. annual) may be required to insure the integrity of the riprap.
- If slippage or displacement occurs, conduct an engineering analysis to determine the cause.
- Overland water flow, excessive seepage, deep slope failure or surficial structural failure should be investigated by an engineer.
- Repair failed areas and/or implement alternate measures to obtain stability.

Riprap Slope Protection

- Inspect periodically to determine if scour has occurred beneath the riprap or filter blanket or dislodged any of the riprap or filter blanket materials.
- Periodic removal of woody vegetation (e.g. annual) may be required to insure the integrity of the riprap.

- If slippage or displacement occurs, conduct an engineering analysis to determine the cause.
- Overland water flow, excessive seepage, deep slope failure or surficial structural failure should be investigated by an engineer.
- Repair failed areas and/or implement alternate measures to obtain stability.

Temporary Erosion Control Blankets

- Inspect temporary erosion control blankets at least once a week and within 24 hours of the end of a storm with a rainfall amount of 0.5 inch or greater for failures during the period of time that they are required until the slope is permanently stabilized.
- Blanket failure has occurred when (1) soils and/or seed have washed away from beneath the blanket and the soil surface can be expected to continue to erode at an accelerated rate, and/or (2) the blanket has become dislodged from the soil surface or is torn.
- If washouts or breakouts occur, reinstall the blanket after regrading and reseeded, ensuring that blanket installation still meets design specifications.
- When repetitive failures occur at the same location, review conditions and limitations for use and determine if diversions, stone check dams or other measures are needed to reduce failure rate.
- Repair any dislodged or failed blankets immediately.

Permanent Erosion Control Blankets

- Inspect permanent turf reinforcement mats at least once a week and within 24 hours of the end of a storm with a rainfall amount of 0.5 inch or greater for failures until the turf has become established.
- Mat failure has occurred when soils and/or seed have washed away from beneath or within the mat resulting in a soil surface that can be expected to continue to erode or when the mat has become dislodged from the soil surface.
- When repetitive failures occur at the same location, review conditions and limitations of turf reinforcement mats and determine if additional controls, (e.g. diversions, stone barriers) are needed to ensure success.
- Repair mat failures within one work day.
- After the turf has become established, inspect annually or after major storm events.

Gabions

- Inspect periodically to determine if high flows have caused scour beneath the gabions or filter blanket or dislodged any of the filter blanket materials.
- Periodic removal of woody vegetation (e.g. annual) may be required to insure the integrity of the gabion.

Cellular Confinement Systems

- Inspect periodically to confirm system is performing as planned.
- Periodic removal of woody vegetation (e.g. annual) may be required to insure the integrity of the cellular confinement system.

Articulated Concrete Blocks

- Inspect periodically to confirm system is performing as planned.
- Periodic removal of woody vegetation (e.g. annual) may be required to insure the integrity of the cellular confinement system.

Good & Bad Practices:

Erosion Control Blanket



- * Excellent installation of soil retention blankets.
- * Remember to entrench the blanket at the top and bottom of the slope.
- * Staple checks are required every 35 feet.



- * Poor installation of soil retention blankets.
- * Blankets should have been staked down and overlapped, and should fully cover the disturbed area.

Troubleshooting Tips: Erosion Control Blanket

Condition	Common Solution
Anchoring is failing. Undercutting is occurring.	Dig trench along the top and bury the blankets. Use staples to anchor according to manufacturer's recommendations.
Undercutting due to inadequate preparation.	Repair the soil surface. Remove rocks, clods and other obstructions. Fill in rills in uneven areas to promote good contact between blanket and soil.
Excessive water flow across stabilized surface.	Use other BMPs to limit flow onto stabilized area or reduce slope length. See Berms, Dikes and Swales, Slope Tracking.
Undercutting occurs along the top of the slope.	Dig a trench along the top of the slope (6"x6") and anchor blanket into trench by back filling and tamping the soil.
Blankets separate along the seams.	Overlap edges of blankets by 6 inches and staple every 3 feet, or according to manufacturer's directions.
Blankets separate where the rolls are attached end to end.	Shingle the blanket so that the top blanket overlaps the bottom blanket by 6 inches and staple through the overlapped areas every 12 inches.
Blanket does not make complete contact with the soil surface.	Prepare the soil surface by removing rocks, clods, sticks and vegetation; fill in uneven areas.
Blanket slipping down the slope.	Re-anchor at top of slope. Use manufacturer's staples/stakes and stapling patterns.

Surface Roughening



Description

- Roughening and “un-compacting” soil surface by creating horizontal ridges and depressions perpendicular to the direction of the slope (on the contour), or by not fine-grading slopes
- Roughening (also known as “grooving” or “tracking”) consists of using any appropriate implement or machine, which can be safely operated on the slope and which will not cause undue compaction, to create a series of tracks.

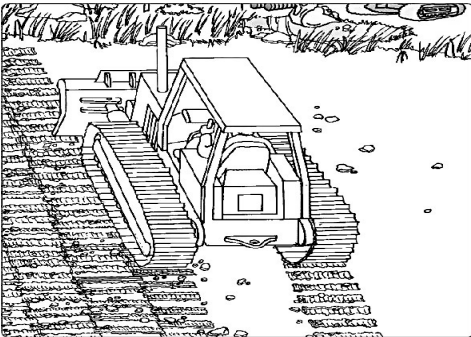

Installation Areas Which Will Not Be Mowed

- Cut Slopes: Grooves shall not be less than 3 inches deep nor further than 15 inches apart.
- Fill Slopes: Shall be grooved or allowed to remain rough as they are constructed.

Installation Areas Which Will Be Mowed

- Areas to be seeded and mowed may be roughened with shallow depressions such as those that remain after harrowing, raking, or using a culti-packer-seeder.
- Depressions formed by such equipment should be at least 1 inch deep and not further than 12 inches apart.

Inspection and Maintenance

Inspect and maintain in accordance with the final surface protection measure(s) used.

Troubleshooting Tips

Condition	Common Solution
Lack of adequate soil cover.	Mulch or appropriately cover to prevent rainfall contact.
Rill erosion occurs.	Regrade and recover.
Slope failure.	Provide adequate collection and conveyance system (e.g., a pipe slope drain). Install trench drain to intercept drainage and groundwater seepage (discharge to approved disposal point).

Good & Bad Practices



- * Grooves or furrows created by Surface Roughening should follow along the contours of the grade, as noted in this example.



- * Inappropriate grading techniques will leave cutting running up and down the vertical plane, which facilitates channeling and erosion.

Check Dams



Description

- Small, normally temporary dams constructed across a waterway or other watercourse.
- Check dams can be constructed of stone, logs or fiber roll.

Inspection and Maintenance

- Temporary check dams shall be maintained in proper working condition by the contractor as long as the structure is in place.
- For temporary check dams, inspect stone check dams at least once a week and within 24 hours of the end of a storm with a rainfall amount of 0.5 inch or greater to determine maintenance needs.
- For permanent stone check dams, inspect and maintain the stone check dam in accordance with the standards and specifications provided in the design.
- Replace or repair the check dam within 24 hours of observed failure.
- Failure of the check dam has occurred when sediment fails to be retained because:
 - stone has moved,
 - soil has eroded around or under the check dam reducing its functional capacity, or
 - trapped sediments are greater than one-half of the height of the check dam.
- When repetitive failures occur at the same location, review conditions and limitations for use and determine if additional controls (e.g. temporary stabilization of contributing area, diversions, stone check dams) are needed to reduce failure rate.
- Maintain the stone check dam until the contributing area is stabilized.
- After the contributing area is stabilized, remove accumulated sediment.

Sediment Removal

- Sediment should be removed from behind the check dams when it has accumulated to one-half of the original height of the dam.
- Trapping efficiencies at check dams are significantly reduced if accumulated sediment is not removed.

Check Dam Removal

- Check dams must be removed when their useful life has been completed.
- In temporary ditches and swales, check dams should be removed and the ditch filled in when it is no longer needed.
- In permanent ditches, check dams should be removed when a permanent lining can be installed.
- Temporary check dams may be removed or graded into the flow line of the channel over the area left disturbed by sediment removal.
- Grade so there are no obstructions to water flow.
- If stone check dams are used in grass-lined channels which will be mowed, remove all the stone or carefully grade out the stone to ensure it does not interfere with mowing. This should include any stone which has washed downstream.
- Stabilize any disturbed soil that remains from check dam removal operations.
- The area beneath the check dams should be seeded and mulched immediately after they are removed.

Good & Bad Practices



- * Correctly installed rock Check Dams will allow flows through and over the feature without bypass or undermining.



- * Straw Bales do not perform well as *Check Dams*.
- * Flows do not penetrate the bales, which creates ponding and hydraulic pressure. This pressure will consistently force the water under the bales, creating erosion from the undermining.

Troubleshooting Tips

Condition	Common Solution
There is too much sediment.	Remove accumulated sediment to recover holding capacity. Remove sediment when it reaches 1/3 the check dam height.
There is insufficient ponding area.	Space check dams farther apart and increase height of dams.
Flow travels around check dam.	Lower center of check dam so that it is 12 inches lower than the channel side.
Dams dislodged by heavy flow.	Reduce drainage area and/or install replacement dam. Consider adding more dams upstream. Use larger size rock. Better anchoring.
Wrong type of materials is used to construct barrier.	Use heavier materials such as larger rocks. Do not use straw bales or silt fence.
Check dams undercut.	Stabilize ditch with erosion control blanket, vegetation, or other controls.
Rills and gullies form in channels between check dams.	Check dams are too far apart. Add more dams and stabilize bottom of ditch.

Water Bars



Description

A ridge or ridge and channel constructed diagonally across a sloping road or utility right-of-way that is subject to erosion.

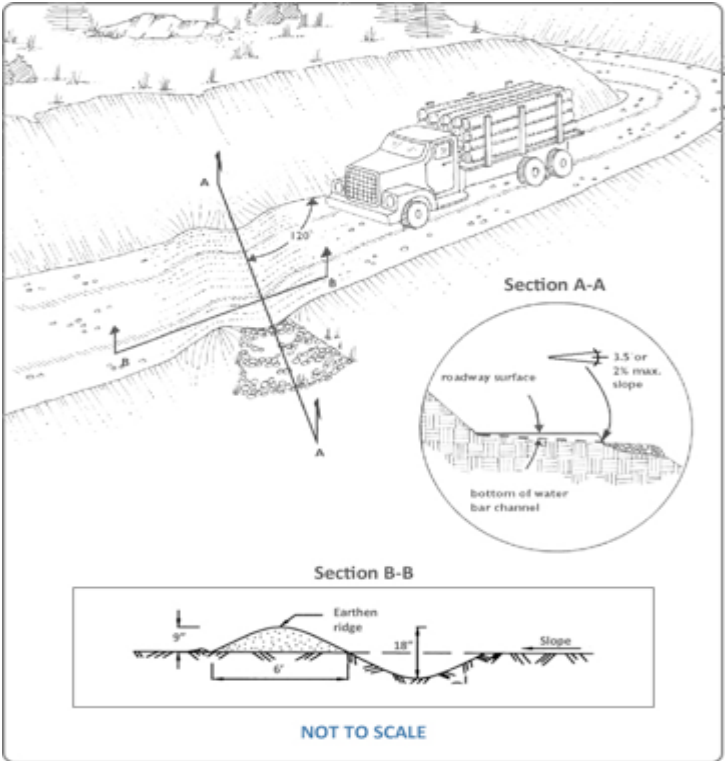

Inspection and Maintenance

- For water bars receiving drainage from disturbed areas, inspect and perform any repair work at the end of each day that the water bar is exposed to vehicular traffic and within 24-hours of the end of a rainfall amount of 0.25-inch or greater.
- For water bars receiving drainage from stable areas, inspect and perform any repair work at the end of each day the water bar is exposed to vehicular traffic or annually, whichever comes first.
- Ensure vehicle crossing has been stabilized with gravel. Exposed areas shall be immediately seeded and mulched.
- Immediately reshape and repair any observed damage to the water bar.
- If sediment deposits reach approximately one-half the height of the water bar, remove the accumulated sediments.
- When water bars have served their usefulness, they may be removed.

Troubleshooting Tips

Condition	Common Solution
Overtopping ridge where diversion crosses low areas.	Build water bars to grade at all points.
Erosion between water bars.	Spacing is too wide for slope so install additional water bars.
Erosion at outlets.	Install outlet stabilization structure or extend upslope water bar so runoff will not converge on lower outlets.
Erosion in channel.	Grade is too steep. Realign water bars.

Diversions



Description

A drainage way of parabolic or trapezoidal cross-section with a supporting ridge on the lower side that is constructed across a slope.

Inspection and Maintenance

- Inspect the diversion at least once a week and within 24 hours of the end of a storm with a rainfall amount of 0.25-inches or greater during construction or until the diversion is completely stabilized.
- Ensure all trees, brush, stumps, obstructions, and other objectionable material have been removed and disposed of to avoid interference with the proper functioning of the diversion.
- Ensure all earth removed and not needed in construction has been spread or disposed of so that it will not interfere with the functioning of the diversion.
- Check for seed and/or mulch movement and/or rill erosion.
- Mow as required for vegetated diversions.
- Remove sediment and repair damage to diversions immediately.
- After construction is complete and the diversion is completely stabilized, inspect the diversion annually and after each major rainfall for damage and deterioration. Repair damages immediately.
- Ongoing maintenance shall include the removal of accumulated sediment and debris from the channel and mowing as required.

Perimeter Dikes



Description

A temporary ridge of soil excavated from an adjoining swale located along the perimeter of the site or disturbed area.

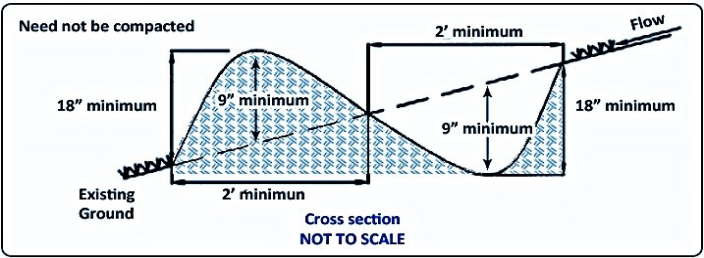

Inspection and Maintenance

- Periodic inspection and required maintenance shall be provided at the end of each work day and after each rain event. Repair as needed.
- Construction traffic should not be permitted to cross the perimeter dike/swale.
- The perimeter dike/swale shall remain in place until the disturbed areas are permanently stabilized.

Troubleshooting Tips: Diversions & Perimeter Dikes

Condition	Common Solution
Erosion in channel from excessive grade.	Install a temporary liner in channel.
Overtopping cause by sediment deposition in channel where grade decreases or reverses.	Deepen channel or realign grade.
Overtopping at low point in ridge where diversion crosses shallow draw.	Reconstruct ridge with positive grade at all points.
Erosion at outlet.	Install outlet stabilization structures, or relocate/redesign outlet to slow runoff velocity and dissipate flow.
Sedimentation at diversion outlet.	Install sediment trap.
Drainage area too large.	Install additional practices to reduce contributing drainage area and prevent erosion and overtopping.
Dikes (berms) not stabilized.	Stabilize exposed soils with temporary seeding, mulch, matting, or rock.
Too steep.	Install matting or riprap to reduce erosion.

Lined Waterways



Description

A waterway, which may include chutes and flumes, with an erosion resistant lining composed of turf reinforcement mat, riprap, gabions, or other appropriate durable material.

Typical Waterway Cross-Section

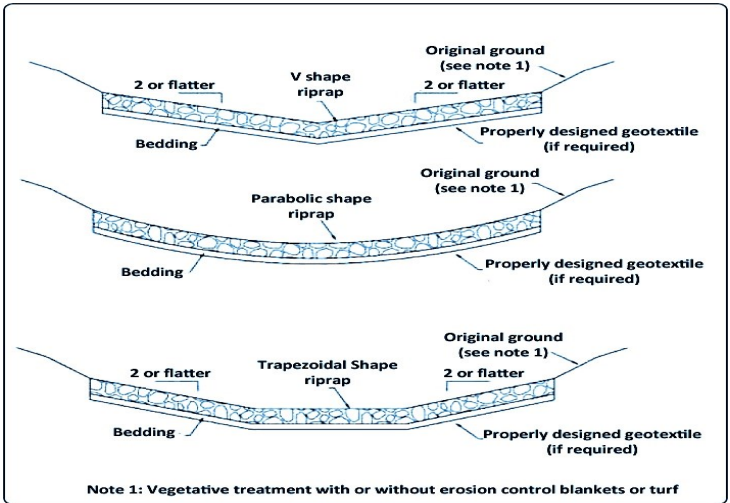

Inspection and Maintenance

- Until the contributing drainage area is stabilized, inspect within 24 hours of the end of a storm with a rainfall greater than 0.25 inches.
- Ensure all trees, brush, stumps, roots, obstructions and other unsuitable materials are removed, properly disposed of, and do not interfere with construction or proper functioning of the permanent lined waterway or unsuitable subgrade that will result in settling.
- Ensure proper removal and disposal of any excess soil.
- Repair lining as required to ensure its long-term stability.

Troubleshooting Tips

See **Vegetated Waterways** (next measure).

Vegetated Waterways



Description

A constructed channel graded in earth materials and stabilized with non-woody vegetation for the non-erosive conveyance of water.

Vegetated Waterways with Stone Center

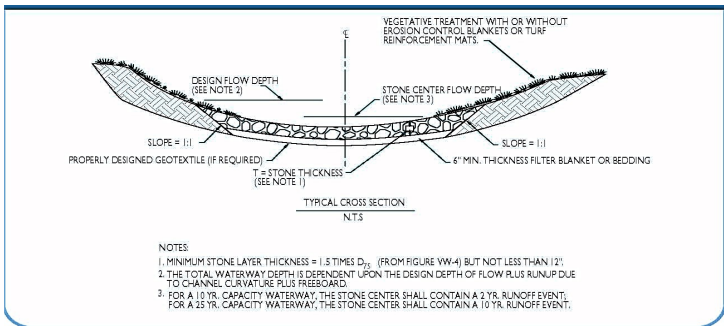

Inspection and Maintenance

- Correct erosion or silt deposition on vegetated waterways by removing the excess material or changing the vegetative cover if possible.
- Protect waterway from concentrated flow by using diversion of runoff or mechanical means of stabilization such as silt fences, mulching, straw bale barriers and etc. to stabilize grade during vegetation establishment.
- Minimize damage to vegetation by excluding foot and vehicular whenever possible, especially during wet periods.
- Inspect grassed waterways regularly, especially following heavy rains. Fill, compact, and reseed damaged areas immediately. Remove sediment deposits to maintain capacity of grassed waterway.

- Avoid use of herbicides that would be harmful to the vegetation (including established forbs) or pollinating insects in and adjacent to the waterway area.
- Mow vegetation to maintain capacity and reduce sediment deposition.
- Apply supplemental nutrients as needed to maintain the desired species composition and stand density of the waterway.
- Control noxious weeds.

Troubleshooting Tips: Vegetated and Lined Waterways

Condition	Common Solution
Vegetation not established.	Use erosion control matting or sod. Install additional outlets or underdrainage system.
Out-of-bank flows are problematic.	Reduce flows to channel, or redesign.
Gullies forming in vegetated channel.	Use liner in center line of vegetated channel.
Erosion beneath rock channels.	Make sure filter fabric was installed.

Temporary Lined Channel



Description

- A channel designed to convey flows on a short term basis and lined with a flexible impermeable geomembrane or other erosion resistant covering to prevent erosion of concentrated flows.
- Temporary lined channels are intended to convey watercourses from substantially larger areas than temporary diversions.

Inspection and Maintenance

- For temporary channels containing impermeable geomembranes, inspect daily for undercutting of and damage to the lining. Repair and patch as needed.
- For temporary channels containing permanent channel linings, inspect at least once a week and within 24 hours of the end of a storm with a rainfall amount of 0.5 inch or greater. Repair as needed.

- Where a pipe slope drain outlets into a sediment trapping device, it shall discharge at the riser crest or weir elevation.
- A riprap apron shall be used below the pipe outlet where clean water is being discharged into a stabilized area.

Inspection and Maintenance

- Inspection and any needed maintenance shall be performed after each storm.
- A temporary slope drain should remain in place up to 30 days after slopes have been completely stabilized.

Good & Bad Practices



- * Slope Drains can function effectively for conveying flows down an unconsolidated grade.



- * Adequate outfall protection is required at the termination point to prevent scouring.

Troubleshooting Tips

Condition	Common Solution
Pipe slope drain shifts on the slope	Add additional strapping on sections of the pipe. Increase the depth of stakes.
Erosion occurs around the inlet and outlet.	Regrade soil and thoroughly compact. Prevent source material movement with additional BMPs such as, flared end sections or lining with geotextile and rock.
Pipe becomes clogged.	Flush out pipe. Place a screen or grate at inlet to capture large materials. Identify source of material and consider additional BMPs.
Excessive sediment accumulates around inlet/outlet.	Remove accumulated sediment and stabilize upstream area.
Pipe slope drain overtops.	Limit drainage area and flow velocity. Check pipe diameter to ensure that it is sized properly to accept flow. Add Additional pipes as necessary.
Pipe rolls or separates.	Stake in place and replace connection bands.

Grade Stabilization Structures



Description

A structure to stabilize the grade or to control “head cutting” in natural or artificial channels and used to lower water from one elevation to another, while reducing or preventing excessive erosion by reducing velocities and grade in the watercourse or providing structures that can withstand the higher velocities.

Inspection and Maintenance

- Once properly installed, the maintenance for the grade stabilization structure should be minimal.
- Inspect the structure periodically and after major storm events.
- Check fill for piping or extreme settlement. Ensure a good vegetative cover.
- Check the channel for scour or debris and loss of rock from aprons.
- Repair or replace failing structures immediately.

Troubleshooting Tips

Condition	Common Solution
Any rills or damage from erosion and animal burrowing.	Repair immediately to avoid further damage
If seeps develop on the slopes.	The area should be evaluated to determine if the seeps will cause an unstable condition. Subsurface drains or a gravel mulch may be required to solve seep problems.
Frozen materials or soft and easily compressible materials present in fills.	Simply should not be used in fills intended to support buildings, parking lots, roads, conduits, or other structures.
Sloughing, erosion or excessive moisture content present.	Controlled by the compaction of fills to the required density. Maximum thickness of fill layers prior to compaction should not exceed 9 inches or as specified by the design engineer.
Areas disturbed	Should be free draining, left with a neat and finished appearance, and should be protected from erosion.

Outlet Protection



Description

- Any of various devices that dissipate energy at the outlet to a diversion, pump, or other water conveyance, including but not limited to:
- **Level Spreader** – Depression with a broad stable discharge constructed at zero grade across a slope
- **Riprap Outlet Protection** – Armored discharge areas that mitigate flow velocities.
- **Plunge Pool** – Similar to riprap outlet protection but incorporates a pool to dissipate energy.
- **Scour Protection Mats** – Rigid manufactured rubber or polypropylene matting systems.
- **Turf Reinforcement Mats** – Non degradable three-dimensional matting designed to reinforce vegetation, allowing the vegetation to withstand high energy flows.

Inspection and Maintenance

Level Spreader

- For temporary installations, inspect the level spreader at least once a week and within 24 hours of the end of a storm with a rainfall amount of 0.25 inch or greater to determine maintenance needs.
- For permanent installations, inspect after major rainstorms or once a year.
- Maintain the level spreader lip at 0.0% slope to allow for proper functioning of the measure.
- Avoid the placement of any material on and prevent construction traffic across the structure.

→ If the measure is damaged by construction traffic, repair it immediately.

Rock Outlet Protection, Scour Protection Mats, Turf Reinforcement Mats, Reno Mattresses, Revetment Mats

→ Once a riprap outlet has been installed, the maintenance needs are very low.

→ It should be inspected after high flows for evidence of scour beneath the riprap or for dislodged stones.

→ Repairs should be made immediately.

Minimum Dimensions for Level Spreader

Design Flow, Q_{10} (cfs)	Depth (ft.)	Width of Lower Side Slope of Spreader (ft.)	Length (ft.)
0 – 10	0.5	6	10
10 – 20	0.6	6	20

Troubleshooting Tips

Condition	Common Solution
Rock protection washes away.	Replace rock protection with larger diameter rock based on the discharge velocity. Consult an engineer for proper rock sizing.
Scour occurs at the end of the rock protection splash pad.	Increase length of rock protections splash pad or stabilize downstream channel with vegetation or synthetic blankets (turf reinforcement mats).
Riprap filled with sediment.	Evaluate upstream soil erosion and sediment control practices. Remove sediment by hand.

Good & Bad Practices



- * Good use of rock as outlet protection.
- * The erosion log above the culvert helps prevent debris and dirt from falling into the outlet.



- * Poor installation of outlet protection.
- * Geotextile was not placed under the riprap and not enough rock was used. As a result, storm-water is undercutting the existing rock.

Inlet Protection



Description

- A temporary, somewhat permeable barrier, installed around inlets in the form of a fence, berm or excavation around an opening, trapping and filtering water and thereby reducing the sediment content of sediment laden water by settling.
- “External inlet protection” products install in or around storm grates. External inlet protection devices are usually fitted to the size of the manhole grate structure. These devices capture sediment before it enters the manhole.
- “Internal inlet protection” products install inside the manhole structure. Internal inlet filters capture sediment after it enters the manhole structure.

Inspection, Maintenance, and Removal Requirements

- Inspect and maintain inlet protection devices are every rain event and/or weekly as required.
- Dispose of sediment properly.
- Remove all inlet protection devices within 30 days of permanent site stabilization.

Excavated Drop Inlet Protection

- Inspect and clean the excavated basin after every storm.
- Sediment should be removed when 50 percent of the storage volume is achieved. This material should be incorporated into the site in a stabilized manner.

Fabric Drop Inlet Protection

- Inspect the fabric barrier after each rain event and make repairs as needed.
- Remove sediment from the pool area as necessary with care not to undercut or damage the filter fabric.
- Upon stabilization of the drainage area, remove all materials and unstable sediment and dispose of properly. Bring the adjacent area of the drop inlet to grade, smooth and compact and stabilize in the appropriate manner to the site.
- If straw bales are used in lieu of filter fabric, straw bales will be replaced every 4 months until the area is stabilized.

Stone and Block Drop Inlet Protection

- The barrier should be inspected after each rain event and repairs made where needed.
- Remove sediment as necessary to provide for accurate storage volume for subsequent rains.
- Upon stabilization of contributing drainage area, remove all materials and any unstable soil and dispose of properly. Bring the disturbed area to proper grade, smooth, compact and stabilized in a manner appropriate to the site.

Curb Drop Inlet Protection

- Any sediment should be removed and disposed of on the site.
- Any stone missing should be replaced.
- Check materials for proper anchorage and secure as necessary.

Manufactured Inlet Filter

- Inspect external devices for damage and clean as necessary.
- Lift internal inlet filters carefully from the drainage structure. Remove any accumulated sediment and reinsert device into the drain opening.
- Remove all accumulated sediment and dispose of properly.

Troubleshooting Tips

Condition	Common Solution
Excessive sediment accumulation behind protection device.	Remove accumulated sediment when it reaches 1/3 the barrier height or 1/3 the holding capacity. Repair bypasses and undercuts promptly.
Excessive sediment is entering the inlet.	Ensure that soil stabilization and sediment control devices are installed upstream of inlets. Ensure that the barriers around the inlet are installed correctly.
Sediment is bypassing silt fence used for inlet protection.	Repair/replace fencing material and re-stake fences that are damaged. Silt fence needs to be keyed in so that water goes through the geotextile and not under it.
Material from broken bags is entering inlet.	Clean out inlet. Remove broken bags and replace as necessary.
Ponded water causes a traffic concern.	Use alternative BMPs upstream. Try installing a manufactured catch basins insert.
Rock filter material clogged.	Pull rocks away from inlet, clean, or replace with new/washed rock.

Good & Bad Practices



- * Good inlet protection filtering sediment-laden water prior to its entry into the drainage system.
- * Fabric is properly secured behind the curb.

- * Geotextile should be anchored behind the curb.

Construction Entrances



Description

A stone stabilized pad, “mud rack”, automotive spray, or other measures located at points of vehicular ingress and egress on a construction site.

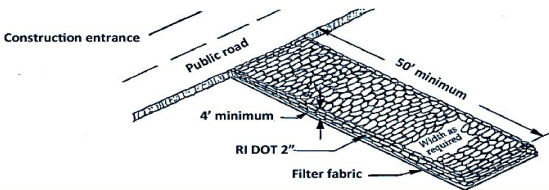

Construction entrance with wash rack



Detail of washrack

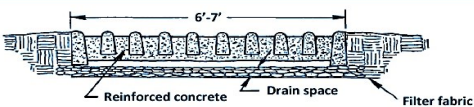

Installation

- Thickness: not less than four (4) inches.
- Width: not less than full width of points of ingress or egress.
- Length: 50 feet minimum where the soils are sands or gravels or 100 feet minimum where soils are clays or silts, except where the traveled length is less than 50 or 100 feet, respectively.
- Aggregate Size: Use ASTM C-33, size No. 2 or 3, or RIDOT 2” size crushed stone or gravel.

→ **Geotextile:** Fibers used in the geotextile shall consist of synthetic polymers composed of at least 85% by weight polypropylenes, polyesters, polyamides, polyethylene, polyolefins or polyvinylidene-chlorides.

Inspection and Maintenance

- The entrance shall be maintained in a condition which will prevent tracking or flowing of sediment onto paved surfaces.
- Provide periodic top dressing with additional stone or additional length as conditions demand.
- Repair any measures used to trap sediment as needed.
- Immediately remove all sediment spilled, dropped, washed or tracked onto paved surfaces.
- Roads adjacent to a construction site shall be left clean at the end of each day.
- If the construction entrance is being properly maintained and the action of a vehicle traveling over the stone pad is not sufficient to remove the majority of the sediment, then either: (1) increase the length of the construction entrance, (2) modify the construction access road surface, or (3) install washing racks and associated settling area or similar devices before the vehicle enters a paved surface.
- Roads adjacent to a construction site shall be clean at the end of each day.
- At the completion of construction all entrance and exit points to the site must be restored in accordance with the approved plans.

Good & Bad Practices



- * Good gravel access approach.
- * Approach extends at least 50 feet from roadway.



- * Lack of gravel access approach.
- * Sediment is being tracked into roadway with a drainage structure nearby.
- * Drainage structure should be protected.

Troubleshooting Tips

Condition	Common solution
Crushed rock compacted into ground.	Install layer of fabric underneath and reapply rock.
Crushed rock full of sediment	Top-dress with additional rock or wash and drain to sediment trapping device.
Dirt tracking from the site.	Add larger rock, increase depth, or increase length of stabilized exit. Install a wheel wash or physically remove surface mud from tires. Conduct street sweeping.
Vehicles are leaving the site from other locations and not using the designated construction exit.	Designate access points and require all employees, subcontractors, and others to use them. Fence or barricade other access points
Aggregate needs to be replaced or replenished.	Rake rock with grubbing attachment or replace material if the pad fills with sediment.
Aggregate material is being incorporated into soil.	Install geotextile under base material.
Runoff leaving the site.	Grade construction entrance/ exit points to prevent runoff from leaving the construction site.
Dust is generated.	Add additional rock or lengthen drive. Use a water truck to keep dust down (control amount and type of spray to minimize erosion) and/or use a wetting agent on roadway.

Temporary Sediment Basins



Description

A temporary dam, excavated pit or dugout pond constructed across a waterway or at another suitable location, with a controlled outlet(s) such that a combination of wet and dry storage areas are created.

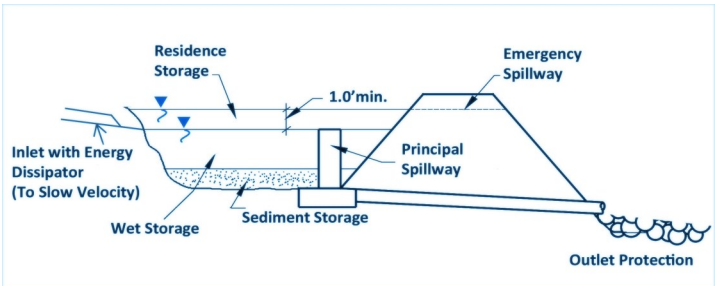

Inspection

→ Inspect the temporary sediment basin at least once a week and within 24 hours of the end of a storm with a rainfall amount of 0.25 inch or greater to determine conditions in the basin.

Chemical Treatment

→ In some instances chemical treatment may be necessary to increase solids settling in the temporary sedimentation basin. (The use of treatment chemicals must be in compliance with **Appendix J, Chemical Treatment for Erosion and Sediment Control** in the RI SESC Handbook).

Maintenance: Sediment Removal

→ Clean the sediment basin of sediments when sediment accumulation exceeds one half of the wet storage capacity of the basin or when the depth of available pool is reduced to 18 inches, whichever is achieved first.

- Sediment levels shall be marked within the sediment storage area by stakes or other means showing the threshold elevation for sediment cleanout.
- Prior to the removal of sediments, dewater the basin through pumping or other means to the expose previously submerged sediments.
- Use measures found in the SESC Handbook sub-section addressing **Dewatering and Sediment Retention and Stockpile and Staging Area Management** when addressing the removal of accumulated sediments.
- Do not allow accumulated sediment to flush into the stream or drainage way.
- Stockpile the sediment in such a manner that it will not erode from the site or into a wetland, watercourse or other sensitive area.
- Sediment removal, transportation and disposal shall occur as shown on the plans as limited by the design criteria.
- Sediment basin designs shall include provisions for the periodic removal of accumulated sediments, including adequate access for excavating and hauling equipment, dewatering and the threshold of sediment deposition that triggers the sediment removal operation.
- Disposal sites for the removed sediments shall be planned. See measures found in the SESC Handbook sub-section on **Dewatering and Sediment Retention and Stockpile and Staging Area Management**.

Removal

- Once the project is completed and all site soils are stabilized the temporary sedimentation basin must be removed and the area must be permanently stabilized.
- In the cases where a temporary sedimentation basin will be utilized as a permanent detention basin, the temporary sediment basin must be modified as specified in the approved plans to prepare it for long term use. In these instances, preparation efforts should, at a minimum, address the removal of any accumulated sediments.

Troubleshooting Tips

See **Temporary Sediment Traps** (next measure).

Good & Bad Practices



- * Typical temporary Sediment Basin, with perforated riser pipe and armored overflow designated as the discharge points.
- * Basins will be sized in relation to the drainage area conveying to the feature.



- * Inspections for *Sediment Basins* need to evaluate sediment accumulations and basin function.
- * Note the displaced riser pipe here.

Temporary Sediment Traps



Description

- A temporary ponding area with a stone outlet formed by excavation and/or constructing an earthen embankment.
- Avoid placing temporary sediment traps directly in the line of flow. If placed in the line of flow, peak flows must be addressed.

Inspection, Maintenance, and Removal Requirements

- Inspect the temporary sediment trap at least once a week and within 24 hours of the end of a storm with a rainfall amount of 0.25 inch or greater.
- Check the outlet to ensure that it is structurally sound and has not been damaged by erosion or construction equipment.
- The height of the stone outlet or weir crest should be maintained at least 1 foot below the crest of the embankment.
- Check for sediment accumulation and filtration performance.
- When sediments have accumulated to one half the minimum required volume of the wet storage, dewater the trap as needed, remove sediments and restore the trap to its original dimensions.
- Dispose of the sediment removed from the basin in a suitable area and in such a manner that it will not erode and cause sedimentation problems.
- The temporary sediment trap may be removed after the contributing drainage area is stabilized.
- If it is to be removed, then the plans should show how the site of the temporary sediment trap is to be graded and stabilized after removal.

Views of a Temporary Sediment Trap Outlet

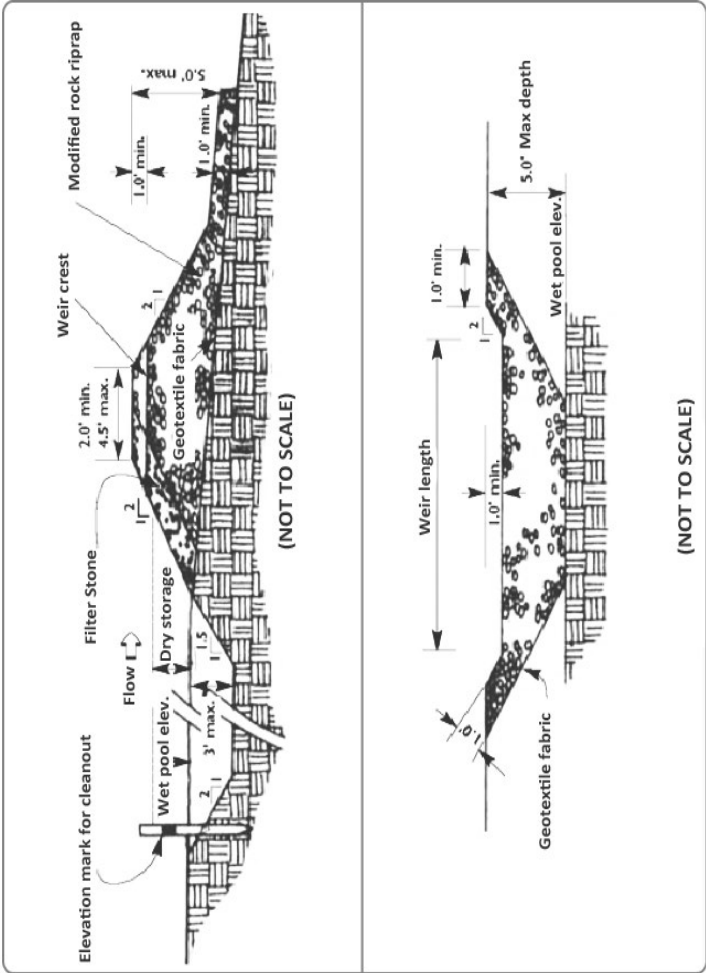

Good & Bad Practices



- *Good trap construction.
- *Check dam has proper overflow notch, and a clearly defined trap.
- *Proper seeding and vegetation in surrounding area.
- *Front and back slopes 1:1 (max).

- *Sediment trap is not deep enough, wide enough, or long enough.
- *Lack of vegetated buffer surrounding waterway.



Troubleshooting Tips: Temporary Sediment Traps & Basins

Condition	Common Solution
Outlet pipe clogged with debris.	Clean pipe, install filter fabric or other similar measure.
Basin slopes eroding.	Stabilize slopes with rock, vegetation, or matting. Pay close attention to inlets.
Excessive sediment buildup.	Remove sediment to retain holding capacity. Do not allow sediment to build up higher than 1 foot below spillway.
Upstream drainage too large.	Have engineer check drainage area calculations. Use other or additional practices.

Temporary Stream Crossings



Description

A temporary stream crossing might be a bridge, a culvert, or a ford that provides streambank stabilization, minimizes sediment loading from construction traffic, and provides a safe, stable way for construction vehicle traffic to cross a watercourse.

Inspection and Maintenance

- Inspect crossings regularly and perform maintenance as needed on and around all structures.
- Equipment must arrive on site in clean condition and is to be maintained carefully. Mud must be removed; the equipment must be free of leaks, invasive species and noxious weeds.
- Wash and maintain vehicles and all service equipment at a designated site well away from the stream bed.

Good & Bad Practices



* Good use of temporary bridge.



* No riprap at approach to prevent sediment from entering the stream.

Troubleshooting Tips

Condition	Common Solution
Slopes of temporary earthen crossing erodes.	Place rock layer on slope sides. Stabilize roadway at crossing.
Sediment and debris block culvert inlet.	Remove sediment and debris as necessary to keep pipe open.
Pipe outlet causes erosion.	Stabilize outlet with riprap or flared end section.
Overtopping occurs.	Incorrect design. Redesign crossing and obtain approval (stamp) of registered civil and/or structural engineer.

Compost Filter Berms



Description

- A compost filter berm is a dike (trapezoidal in cross section) of compost or a compost product that is placed perpendicular to sheet flow runoff to control erosion in disturbed areas and retain sediment.
- Compost may be made from municipal yard trimmings, food residuals, separated municipal solid waste, biosolids, and manure
- Typical compost or mulch berms are constructed a minimum of one (1) foot high and three (3) feet wide.

Inspection, Maintenance, and Removal Requirements

- Compost filter berms should be inspected regularly, as well as after each rainfall event, to ensure that they are intact and the area behind the berm is not filled with silt.
- Inspect for damage and replace or repair damaged sections as needed.
- Accumulated sediments should be removed from behind the berm when the sediments reach approximately one-third to one-half the height of the berm.
- Any areas that have been washed away should be replaced.
- If the berm has experienced significant washout, a filter berm alone may not be the appropriate BMP for this area.

- Depending upon the site-specific conditions, the site operator could remedy the problem by increasing the size of the filter berm or adding another BMP in this area, such as an additional compost filter berm or compost filter sock, a compost blanket, or a silt fence.
- Remove all devices once permanent erosion control measures are in place and functioning.
- Compost can easily be worked into the soil at time of final stabilization.

Troubleshooting Tips

Condition	Common Solution
System is clogged and is not filtering.	Remove and replace filtration media. Clean and reuse if material is suitable. Provide additional upslope erosion prevention or sediment control BMPs

Silt Fence



Description

A temporary barrier of geotextile fabric installed on the contours across a slope.

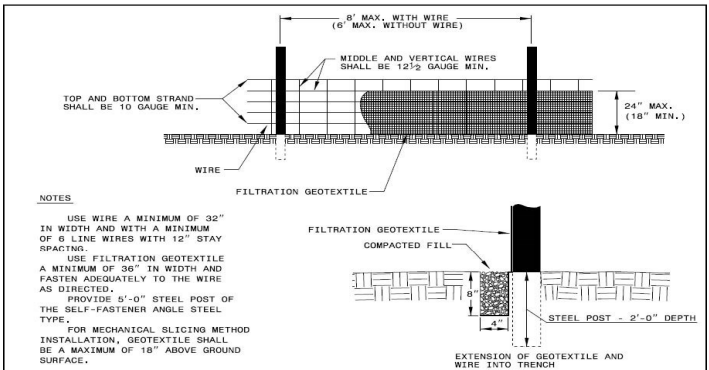

Installation

- Fabric specifications shall meet or exceed the values as listed on the following page.
- Fence Posts (for fabricated units): The length shall be a minimum of 36 inches long. Wood posts will be of sound quality hardwood with a minimum cross sectional area of three (3) square inches. Steel posts will be standard T and U section weighing not less than one (1) pound per linear foot.
- Posts shall be set at a minimum of 8 feet on center.

- Wire Fence (for fabricated units): Wire fencing shall be a minimum 14 gage with a maximum six (6) in. mesh opening, or as approved.
- All silt fences shall be placed at least 10 feet from the toe of a slope to allow for maintenance and roll down.
- Where ends of filter cloth come together, they shall be overlapped, folded and stapled to prevent sediment bypass.
- Fabric should be buried at least six inches deep.
- Termination points should be extended uphill at least six (6) feet.
- Where ends of filter cloth come together, they shall be overlapped, folded and stapled to prevent sediment bypass.
- Sensitive areas to be protected by silt fence may need to be reinforced by using heavy wire fencing for added support to prevent collapse.

Fabric Specifications

<u>Fabric Properties</u>	<u>Minimum Acceptable Value</u>	<u>Test Method</u>
Grab Tensile Strength (lbs)	90	ASTM D1682
Elongation at Failure (%)	50	ASTM D1682
Mullen Burst Strength (PSI)	190	ASTM D3786
Puncture Strength (lbs)	40	ASTM D751 (modified)
Slurry Flow Rate (gal/min/sf)	0.3	
Equivalent Opening Size	40-80	US Std Sieve CW-02215
Ultraviolet Radiation Stability (%)	90	ASTM G-26

Inspection, Maintenance, and Removal Requirements

- Remove all devices once permanent erosion control measures are in place and functioning unless devices are designed to remain in place.
- Inspect regularly for water undercutting and bypassing of devices.

- Inspect for damage and replace or repair damaged sections as needed.
- Remove sediment when it reaches 1/2 the height of the device.
- Silt fence will not be left to rot in place. The silt fence may be removed only when the adjacent exposed area is stabilized, i.e., the area has an established grass or stone cover or has been paved, and is free from future uncontrolled discharges.
- Immediately upon removal of the silt fence the remaining exposed areas will be finished as specified above in plans.

Good & Bad Practices



*Good use of silt fence with stakes installed properly.



- *Poor attention to silt fence maintenance.
- *Do not pile materials on fence.
- *Remove collected sediment before it reaches halfway up the fence.

Troubleshooting Tips

Condition	Common Solution
Excessive sediment accumulation.	Remove accumulated sediment before it reaches 1/3 of the distance up the fence. Apply erosion controls upslope to reduce sediment in runoff.
Flow undermining fence.	Trench, place geotextile, and backfill.
Lack of sufficient ponding area.	Fence should be installed with at least a 3-foot setback from the toe of slope where possible.
Erosion occurs around barrier ends or runoff escaping around end.	Extend fence and turn ends up-slope.
Slope draining to fence is too steep.	Increase setback of silt fence away from the toe of slope. Shorten slope length using wattles or equivalent.
Fence is installed in concentrated flow area.	Identify source of concentrated flow and reevaluate placement of silt fence. Replace fence with check dams.
Posts placed on uphill side of the silt fence.	Reinstall posts 5-10 feet apart on downhill side.
Posts are too far apart and geotextile is sagging.	Posts should be a minimum of 6 feet apart. Install additional posts as needed.
Posts broken or bent over. Potential damage to silt fence.	Replace fence stakes. If required, repair/replace fencing material and re-stake fences that are damaged.

Straw Wattles, Compost Tubes and Fiber Rolls



Description

- Compost Filter Socks: Three-dimensional tubular filtration devices constructed by filling a mesh tube with a compost filter media.
- Straw Wattles: Straw-filled tubes of flexible netting materials. Commonly used filler materials include wheat and rice straw.
- Fiber rolls: Wood excelsior or coconut fiber filled tubes of flexible netting materials.

Installation

- Install fiber rolls in shallow trenches dug 3 to 5 inches deep for soft, loamy soils and 2 to 3 inches deep for hard, rocky soils.
- Trenching is not required. Compost filter socks shall be placed over the top of ground, wooden stakes shall be driven through the center of the filter socks to anchor them to the ground.

Inspection, Maintenance, and Removal Requirements

General

- Remove all devices once permanent erosion control practices are in place and functioning unless devices are designed to remain in place (i.e. compost filter socks with seed).

Straw Wattles and Fiber Rolls

- Straw Wattles and Fiber Rolls are usually left along slopes and are biodegradable
- Sediment removal and disposal are still required in areas where sediment accumulates to at least one-half the distance between the top of the fiber roll or wattle and the ground surface.

Compost Filter Socks

- Compost filter socks should be inspected regularly, as well as after each rainfall event, to ensure that they are intact and the area behind the sock is not filled with sediment.
- If the filter sock was overtopped during a storm event, the operator should consider installing an additional filter sock on top of the original, placing an additional filter sock further up the slope, or using an additional BMP in conjunction with the sock(s).
- Inspect compost socks regularly, and after each rainfall event, to ensure that they are intact and functioning correctly.
- Remove sediment that builds up behind the sock before it interferes with the functionality of the sock.
- Deposit the removed sediment within the project limits or dispose of legally so that the sediment is not subject to erosion by wind or by water.
- Repair or replace split, torn, or unraveling socks.
- Replace broken or split stakes.
- Sagging or slumping compost socks must be repaired with additional stakes or replaced.
- Repair or replace at locations where rills and other evidence of concentrated runoff have occurred beneath the socks.

Troubleshooting Tips

Condition	Common Solution
Excessive sediment accumulation on upslope side of wattles/ tubes/ rolls.	Remove accumulated sediment before it reaches 1/3 of the distance up the wattles/ tubes/rolls. Apply erosion controls upstream to reduce sediment in runoff.
Wattles/ tubes/rolls split, tear, unravel, or become ineffective.	Replace immediately.
Runoff flows along wattles/ tubes/ rolls and discharges around end.	Make sure wattles/ tubes/rolls are placed on a contour and turn ends up-slope.
Runoff flows between, under, or around wattles/ tubes/rolls	Add additional materials and ensure wattles/ tubes/rolls are butted tightly together. Reinstall with proper staking and entrenchment.

Good & Bad Practices



- * Good example of straw wattle installed as perimeter control/ sediment barriers for small area of disturbance with no run-on.



- * Straw Wattle needs to be adequately secured down.
- * The stakes for this installation were driven along the sides, instead of through the wattles.

Straw Bale



Description

- A straw bale barrier is a temporary entrenched and anchored barrier used to intercept sediment-laden runoff and to provide some retention of sediment from small drainage areas.
- Bales shall be a minimum of 30 inches long and a minimum of 14" tall by 18" wide.
- Bale weight shall not be less than 50 pounds and shall be bound with no less than two strings or wires and contain as a minimum five (5) cubic feet of material.
- The useful life span is normally 3 months, therefore straw bales must be replaced or a new barrier placed directly upslope of the old when a barrier is required for longer time periods.

Installation

- A 4 to 6 inch deep trench should be excavated to the length of the barrier and the width of the bale.
- Excavated material is to be placed on the upstream side of the trench.
- Wire or string-bound bales containing a minimum 5 cubic feet of straw are placed in the trench and should be anchored by two 1" x 1" wooden oak stakes that are three (3) feet long or #4 rebar steel pickets driven through the bale into the underlying soil at a slight upstream angle.
- All rebar stakes must be capped with a safety cap.
- The first stake should also be driven slightly toward the previously laid bale to force them together.

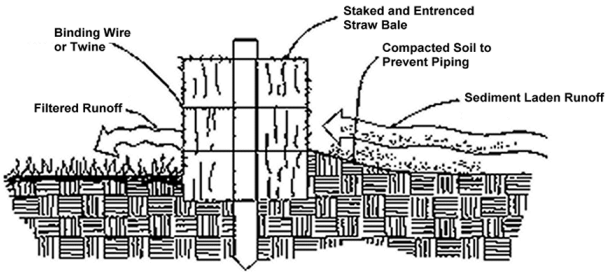

Inspection, Maintenance, and Removal Requirements

- Bale barriers should be inspected immediately after each rainfall or daily during periods of prolonged rainfall.
- Damaged bales and undercutting or flow channels around the ends of barriers should be repaired or corrected as soon as possible.
- Sediment deposits should be removed after each rainfall, and accumulations should be removed when they reach 1/2 the height of the barrier.
- After all sediment-producing areas have been permanently stabilized, all sediment accumulation at the barrier trap should be removed, and all excavation should be backfilled and properly compacted and stabilized.
- Smooth the site to blend with the terrain or as specified on plans.

Common Problems for Inspection

- Drainage area too large; break up into smaller areas.
- Too much sediment accumulation allowed before clean out; too much sediment accumulation may cause barrier to fail.
- Upstream slope too steep or too long; break up length with additional rows of barriers.
- Undercutting occurs; bales were not trenched at least 4 inches or compacted properly.
- Loose spots or spacings not tightly chinked with loose hay; this may result in insufficient trap efficiency.
- Erosion around barrier ends due to endpoints being lower than top of temporary pool elevation; reshape ends to elevation above pool level.

Troubleshooting Tips

Condition	Common Solution
Concentrated runoff or sediment flows are coming around or under straw bale.	Add additional materials and align to contain flows. Reinstall with proper staking and inset.
Sediment is overwhelming the barrier.	Add erosion prevention or other sediment control BMPs. Clean sediment from behind bales.

Good & Bad Practices



- * Straw Bales are securely staked and entrenched.



- * Straw Bales are not entrenched at least 4 inches and stakes are not driven through the bale.

Turbidity Curtains



Description

A flexible, impenetrable barrier (or "curtain") that is weighted at the bottom to achieve closure while supported at the top through a flotation system.

- The height of the curtain shall be 20 percent greater than the depth of the water to allow for water level fluctuations.
- At a minimum, the curtain material shall be supported by a flotation material having over 29 lbs/ft buoyancy.
- The floating curtain shall have a 5/16" galvanized chain as ballast and dual 5/16" galvanized wire ropes with a heavy vinyl coating as load lines.
- In the event that more than one width of fabric is required, a 6" overlap of the material shall also be required.
- The curtain material shall be made of a tightly woven nylon, plastic or other non-deteriorating material meeting the following specifications:

Property Value

Grab tensile strength *md-370 lbs *cd-250 lbs

Mullen burst strength 480 psi

Trapezoid tear strength *md-100 lbs *cd-60 lbs

Apparent opening size 70 US standard sieve

Percent open area 4% permittivity 0.28 sec-1

*md - machine direction

*cd - cross machine direction

Inspection, Maintenance, and Removal Requirements

- The turbidity curtain shall be inspected daily and repaired or replaced immediately.
- If the curtain is oriented in a manner that faces the prevailing winds, frequent checks of the anchorage shall be made.
- It is not normally necessary to remove sediment deposited behind the curtain; but, when necessary, removal is usually done by hand prior to removal of the barrier.
- All removed silt is stabilized away from the waterbody.
- Sediment removal will be at the direction of the regulatory agency.
- The barrier shall be removed by carefully pulling it toward the construction site to minimize the release of attached sediment.
- Any floating construction or natural debris shall be immediately removed to prevent damage to the curtain.

Troubleshooting Tips

Condition	Common Solution
Turbid water released from curtain.	Repair/replace parts as needed. Reevaluate curtain strength versus strength of water flows.

Containment Areas for Earth Materials



Description

A procedure that uses a perimeter earthen berm and excavation to create a containment area where excessively wet soil is placed to allow for the draining of water or evaporation of excessive moisture.

Non-Engineered Dewatering Containment Area for Earth Materials

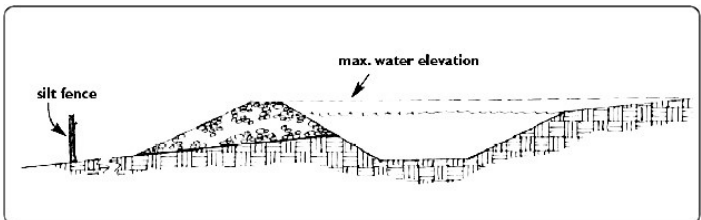
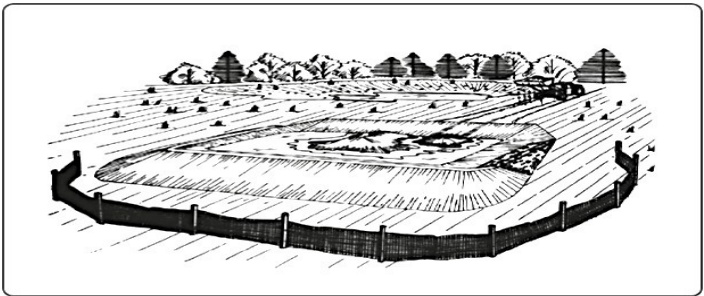

Inspection, Maintenance, and Removal Requirements

- Inspect containment area and associated sediment controls on a daily basis while dewatering operations are active.
- When dewatering operations are not active, inspect at least once every seven (7) calendar days and within twenty-four (24) hours after any storm event which generates at least 0.25 inches of rainfall per twenty four (24) hour period and/or after a significant amount of runoff.
- If the containment berm fails, determine the cause of the failure.
- Repair and clean out perimeter erosion and sediment controls as needed.

Troubleshooting Tips

Condition	Common Solution
Any area where required vegetation has been eroded or removed, or any measure removed.	Vegetation and/or measure replaced within 24 hours.
Berm failure due to overtopping.	Repair the berm and any damage caused by the berm failure and reduce usage of the containment area such that overtopping is prevented.
Berm experiences internal structural failure.	Cease using the containment area. Add additional controls to contain eroded sediments Repair the damage caused by berm failure, and before repairing the berm have the dewatering operation reviewed by an engineer for repair requirements.

Portable Sediment Tanks and Bags



Description

- “Frac tanks” are impermeable containers into which sediment laden water is pumped and temporarily stored while settling and fractionation is achieved.
- Dewatering bags are made from durable geotextile filter fabric suitable for removal of sediment, and designed to accommodate discharge pipes. They may be placed in dumpster or truck bed for ease of removal once sediment has been collected.

Geotextile Dewatering Bag on Geotextile and Stone Pad

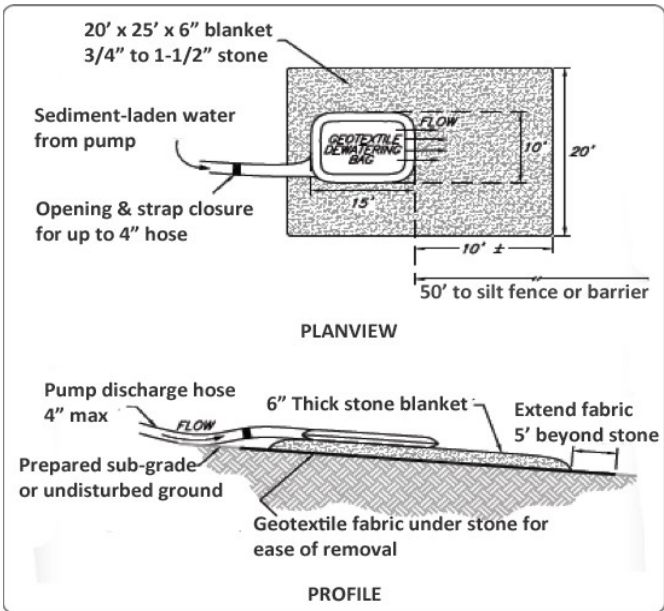

Inspection, Maintenance, and Removal Requirements

Tanks

- Inspect the sediment tank continuously during use.
- Once the water level nears the top of the tank, either shut off the pump while the tank drains and additional capacity is made available, or transport the tank to an appropriate disposal site.
- For a tank that is used to transport the pumped water to a location distant from the pumping operations, discontinue pumping long enough to change the tank.
- Any transported discharge of water and cleaning of the tank shall be done in such a manner as to prevent sediment laden water from reaching a wetland, stormwater collection system, watercourse or paved travelway.

Bags

- Inspect the sediment tank continuously during use.
- Care should always be taken to properly monitor performance to ensure that pump rates or concentrations of sediment are not excessive.

Troubleshooting Tips

Condition	Common Solution
Tank is discharging water while the pumping operation is ongoing and when the wet storage area has lost one half of its volume to sediment build up	Discontinue pumping and remove accumulated sediments or replace the tank.
Sediment tank or sediment bags have reached their maximum capacity to retain sediments	Units shall be taken offline and any retained sediments shall be disposed of properly.
Sediment accumulated to one-half design volume of bag	Remove and restore to its original dimensions and deposit in a suitable area and in such a manner that it will not erode.

Pumping Settling Basins



Description

Pumping Settling Basins utilize an enclosed sediment barrier or excavated pit constructed with stable sides, an inlet and an outlet.

Inspection, Maintenance, and Removal Requirements (with Troubleshooting Tips)

- The lifespan and maintenance frequency necessary to keep these functioning properly will vary greatly based on site-specific conditions.
- During the active dewatering process, the dewatering facility should be reviewed at least daily, with more frequent or continuous supervision as warranted by site conditions.
- Regular cleaning of inlets for underground outlets. Repair or replacement of inlets damaged by equipment.
- Removal of sediment around inlets to ensure that the inlet remains the lowest spot in the basin.
- Special attention should be paid to the outlet area for any sign of erosion or concentration of flow that may damage the buffer's vegetation or underlying soil.
- Where vegetation is specified, regular mowing and control of trees and brush. Vegetative disturbance should be scheduled to avoid peak nesting season.

→ The visual quality of the effluent should be monitored to assess whether or not additional treatment may be necessary to prevent sedimentation of sensitive downstream receptors.

→ At the conclusion of the dewatering process the pumping settling basin area must be cleaned of all accumulated sediments and fully stabilized in accordance with the approved plans.

Pumping Settling Basins– Excavated with Straw Bale Barrier

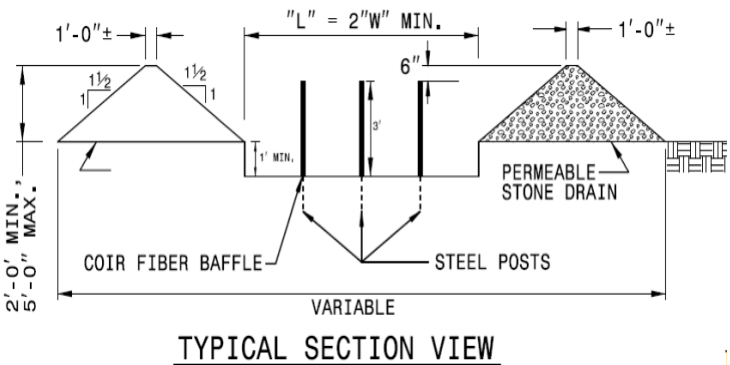
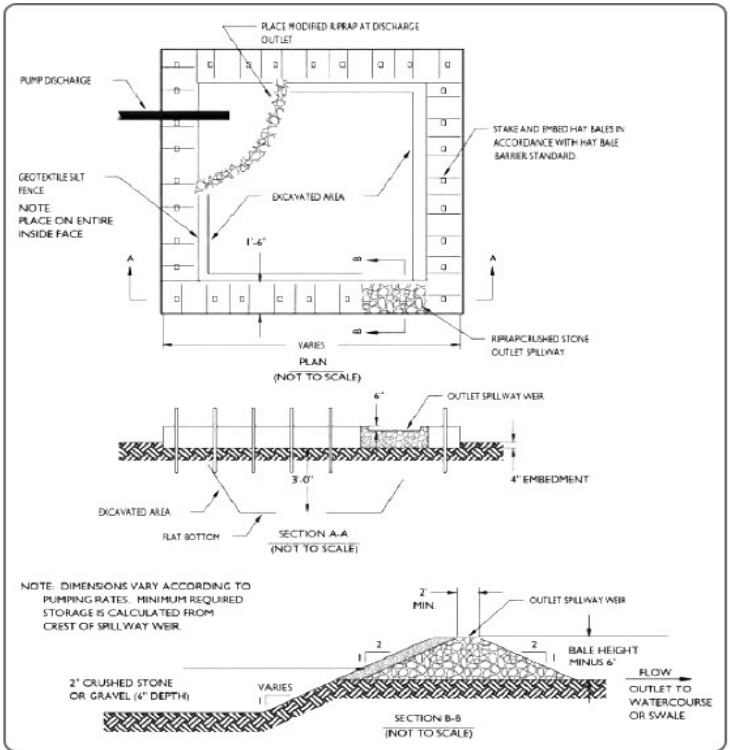

Pump Intake Protection



Definition

Pump Intake Protection uses structures or other protective devices, such as barrels, boards, stones, strainers and floats, which are attached to intake and discharge hoses to prevent the excessive pumping of sediments at the intake and erosion at the point of discharge.

Pump Intake Protection Using Stone Filled Sump with Standpipe

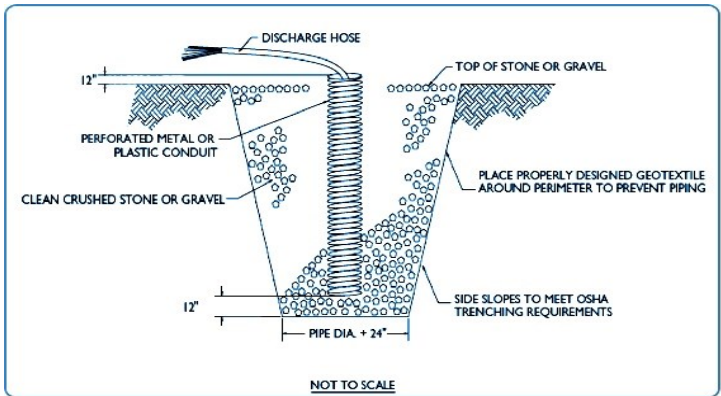

Inspection and Maintenance (with Troubleshooting Tips)

- Monitor pumping operations and adjust pumping rates as needed to keep the construction area dewatered, and minimize the pumping of sediment.
- Inspect the pumping sump, pump intake protection and pump discharge conditions frequently during dewatering operations for proper functioning of equipment.

- Prompt repair or replacement of damaged components.
- Regular cleaning of inlets for underground outlets. Repair or replacement of inlets damaged by equipment.
- Removal of sediment around inlets to ensure that the inlet remains the lowest spot in the basin.
- The lifespan and maintenance frequency necessary to keep these best management measures functioning properly will vary greatly based on site specific conditions.
- Frequent inspection and maintenance is required to minimize the pumping of sediment during dewatering operations.

Photograph Citations

All photographs and figures not specifically mentioned in the following photograph citation list are cited in the Rhode Island Soil Erosion and Sediment Control Handbook.

Protecting Vegetated Buffers: Good Practice:

Montgomery County, Maryland - Department of Environmental Protection (My Green Montgomery)

Protecting Vegetated Buffers: Bad Practice:

[https://tse1.mm.bing.net/th?](https://tse1.mm.bing.net/th?&id=OIP.M2ebb25172c9b23f17341019a3be536a4o0&w=213&h=141&c=0&pid=1.9&rs=0&p=0&r=0)

[&id=OIP.M2ebb25172c9b23f17341019a3be536a4o0&w=213&h=141&c=0&pid=1.9&rs=0&p=0&r=0](https://tse1.mm.bing.net/th?&id=OIP.M2ebb25172c9b23f17341019a3be536a4o0&w=213&h=141&c=0&pid=1.9&rs=0&p=0&r=0)

Limit of a Work & Site Access Control: Good Practice:

Erosionworks.net

Limit of a Work & Site Access Control: Bad Practice:

[https://tse1.mm.bing.net/th?](https://tse1.mm.bing.net/th?&id=OIP.M9ecb66ed124c5a91aa714a44244e37f8o0&w=281&h=198&c=0&pid=1.9&rs=0&p=0&r=0)

[&id=OIP.M9ecb66ed124c5a91aa714a44244e37f8o0&w=281&h=198&c=0&pid=1.9&rs=0&p=0&r=0](https://tse1.mm.bing.net/th?&id=OIP.M9ecb66ed124c5a91aa714a44244e37f8o0&w=281&h=198&c=0&pid=1.9&rs=0&p=0&r=0)

Dust Control- Good and Bad Practices:

MDOT Construction Site Soil Erosion & Pollution Prevention Pocket Guide.

Stockpile and Staging Area Management - Good and Bad Practices :

CDOT Erosion Control and Stormwater Quality Field Guide

Street Sweeping - Good Practice:

CDOT Erosion Control and Stormwater Quality Field Guide

Street Sweeping - Bad Practice:

County of Sacramento Department of Water Resources

Waste Management - Good and Bad Practices:

MDOT Construction Site Soil Erosion & Pollution Prevention Pocket Guide.

Concrete Washout - Good Practice:

University of Arkansas System Division of Agriculture

Concrete Washout - Bad Practice:

Health and Safety Executive

Mulching - Good and Bad Practices:

MT BMP Field Guide

Seeing for Temporary / Permanent Vegetative Cover -

Good and Bad Practices:

MDOT Construction Site Soil Erosion & Pollution Prevention Pocket Guide.

Sodding - Good Practice:

Willowlee Sod Farms

Sodding - Bad Practice:

http://farm3.staticflickr.com/2664/4139287699_242de49aec_z.jpg?zz=1

Landscape Planting - Good Practice:

www.coastalfarm.com

Landscape Planting - Bad Practice:

treedictionary.com

Retaining Wall - Retaining Wall Failure:

NACHI

Retaining Wall - Good Practice:

US DOT FHWA

Retaining Wall - Bad Practice:

<https://tse1.mm.bing.net/th?id=OIP.M64cf12ffb5bf442b267653b01f39077aH0&w=299&h=224&c=0&pid=1.9&rs=0&p=0&r=0>

Slope Protection - Good and Bad Practices:

CDOT Erosion Control and Stormwater Quality Field Guide

Surface Roughening - Good and Bad Practices:

MT BMP Field Guide

Check Dams - Good and Bad Practices:

MT BMP Field Guide

Pipe Slope Drains - Good and Bad Practices:

MT BMP Field Guide

Outlet Protection - Good and Bad Practices:

CDOT Erosion Control and Stormwater Quality Field Guide

Inlet Protection - Good and Bad Practices:

MDOT Construction Site Soil Erosion & Pollution Prevention Pocket Guide.

Construction Entrances - Title : US EPA

Construction Entrances - Good and Bad Practices:

MDOT Construction Site Soil Erosion & Pollution Prevention Pocket Guide.

Temporary Sediment Basins - Good and Bad Practices:

MT BMP Field Guide

Temporary Sediment Traps - Good and Bad Practices:

MDOT Construction Site Soil Erosion & Pollution Prevention Pocket Guide.

Temporary Stream Crossings - Good and Bad Practices:

CDOT Erosion Control and Stormwater Quality Field Guide

Silt Fence - Good and Bad Practices

MDOT Construction Site Soil Erosion & Pollution Prevention Pocket Guide.

Straw Wattles, Compost Tubes and Fiber Rolls - Good and Bad Practices:

MT BMP Field Guide

Straw Bale - Good and Bad Practices:

City of ScottsBluff, Nebraska: Erosion & Sediment Control Guidebook

Pumping Settling Basins - Title :

State of California Department of Transportation – Field Guide to Construction Site Dewatering